

---

PERMIT ATTACHMENT

APPENDIX VIII

SPENT CARBON CONTAINER SPECIFICATIONS

This document was not altered from the April 2016 Application.

September 2018

---

APPENDIX VIII

SPENT CARBON CONTAINER SPECIFICATIONS

FOR

SIEMENS INDUSTRY, INC.

PARKER REACTIVATION FACILITY

PARKER, ARIZONA

Revision 2  
April 2012

## TABLE OF CONTENTS

### Table of Container Volumes

<b><u>DRAWING NO.</u></b>	<b><u>DESCRIPTION</u></b>
ASC200GENASSY	ASC 200 General Assembly
ASC1000SHEET1	ASC1000 General Assembly
ASC2000SHEET1	ASC2000 General Assembly
PV1000SHEET1	PV1000 General Assembly
PV2000SHEET1	PV2000 General Assembly
RB20 OS A SIZE	RB20 General Assembly
RB10 OSGENASSY	RB10 OS General Assembly
RB12HVGENASSY	RB12HV General Assembly
RB20 8X11	RB20 General Assembly
2220	1800 Cu. Ft Aluminum Pneumatic Semi
VSC200GENASSY	VSC200 General Assembly
VSC400	VSC400 General Assembly
VSC1000SHEET1	VSC1000 General Assembly
VSC2000SHEET1	VSC2000 General Assembly
VSC2000GENASSY	Vapor Scrub Assembly VSC 2000
VSC3000GENASSY	VSC3000 General Assembly

**Table of Container Volumes**

<b>Container Type</b>	<b>Volume (ft<sup>3</sup>)</b>	<b>Volume (US Gallons)</b>
VSC/ASC 200/Drums	7.9	59
VSC/ASC 400	17.5	131
VSC/ASC 1000	44.9	336
VSC/ASC 2000	82.0	614
VSC 3000	164	1228
PV1000	44.9	336
PV2000	82.0	614
“Supersack”	Up to 67	Up to 500

This table represents information for the major types of containers managed at the facility. Other containers of various volume and configuration are also received, however, these miscellaneous containers fall within the range of volumes shown.

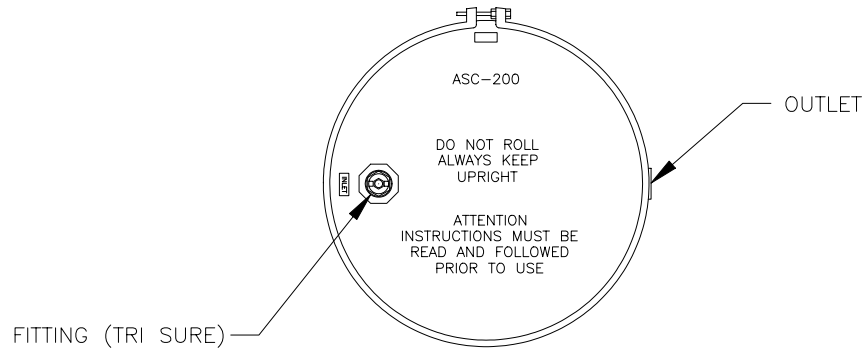

**NOTES:**

1. CARBON:  
AS REQUIRED.
2. MATERIALS OF CONSTRUCTION:  
VESSEL: .....CARBON STEEL  
EXTERNAL COATING: .....HIGH GLOSS PAINT, WESTATES BLUE  
INTERNAL COATING: .....CURED EPOXY  
INTERNAL DISTRIBUTION: .....PVC
3. SPECIFICATIONS:  
FLOW \* - GPM (MAX): ..... 10  
PRESSURE - PSIG (MAX): ..... 15  
TEMPERATURE - DEG F (MAX): ..... 140  
CARBON FILL VOLUME - CU FT: ..... 6.9  
CROSS SECTION - SQ FT: ..... 2.8  
SHIPPING WEIGHT - LBS: (APPROX,) ..... 250  
OPERATING WEIGHT - LBS: (APPROX,) ..... 500

\* NOTE: ACTUAL DESIGN SHOULD BE BASED ON SUPERFICIAL BED VELOCITY (SBV) AS REQUIRED FOR SPECIFIC CONTAMINANTS.

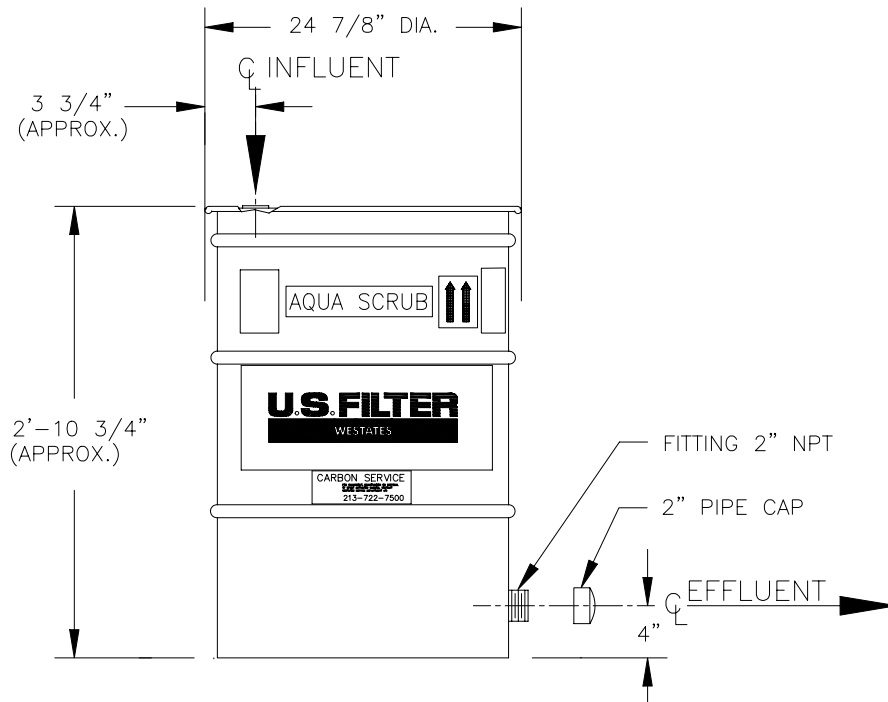

COMPANY CONFIDENTIAL  
THIS DOCUMENT AND ALL INFORMATION CONTAINED HEREIN ARE THE PROPERTY OF THE USFILTER AND/OR ITS AFFILIATES ("USF"). THE DESIGN CONCEPTS AND INFORMATION CONTAINED HEREIN ARE PROPRIETARY TO USF AND ARE SUBMITTED IN CONFIDENCE. THEY ARE NOT TRANSFERABLE AND MUST BE USED ONLY FOR THE PURPOSE FOR WHICH THE DOCUMENT IS EXPRESSLY LOANED. THEY MUST NOT BE DISCLOSED, REPRODUCED, LOANED OR USED IN ANY OTHER MANNER WITHOUT THE EXPRESS WRITTEN CONSENT OF USF. IN NO EVENT SHALL THEY BE USED IN ANY MANNER DETRIMENTAL TO THE INTEREST OF USF. ALL PATENT RIGHTS ARE RESERVED. UPON THE DEMAND OF USF, THIS DOCUMENT, ALONG WITH ALL COPIES AND EXTRACTS, AND ALL RELATED NOTES AND ANALYSES, MUST BE RETURNED TO USF OR DESTROYED, AS INSTRUCTED BY USF. ACCEPTANCE OF THE DELIVERY OF THIS DOCUMENT CONSTITUTES AGREEMENT TO THESE TERMS AND CONDITIONS.

DESIGNER AJA	DATE 2-13-01	TITLE ASC 200 GENERAL ASSEMBLY	
CHECKER	DATE	CLIENT	
ENGINEER	DATE	 USFILTER/WESTATES RED BLUFF, CA 1-800-795-2664	
MANAGER	DATE		
FILE:		PROJECT	REV
SCALE: NONE		DRAWING ASC200GENASSY	SHEET OF

LIST OF COMPONENTS

ITEM	QTY	DESCRIPTION
1	1	TANK ASSEMBLY
2	1	SKID ASSEMBLY
3	1	MANWAY ASSEMBLY, 18" DIA.
4	1	PLATE, I.D. & SERIAL NUMBER
5	1	BRONZE BALL VALVE, 3/4"
6	1	DECAL, "FOR WATER USE ONLY", 2 1/2" x 4 1/4"
7	2	DECAL, "AQUA-SCRUB", WHITE MYLAR
8	2	DECAL, "25 PSIG MAX", WHITE MYLAR
9	2	DECAL, "USFILTER/WESTATES" WHITE MYLAR W/BUE LETTERS

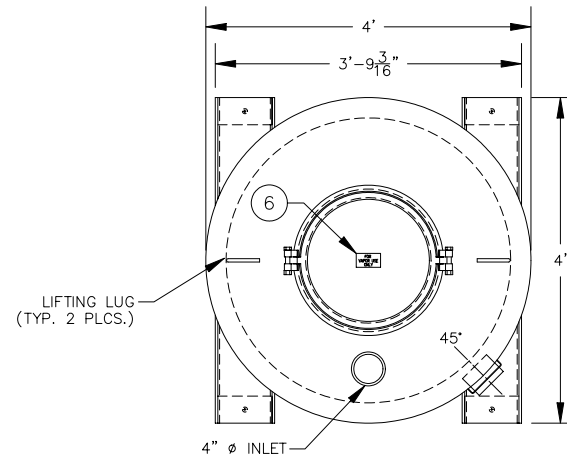

PLAN VIEW

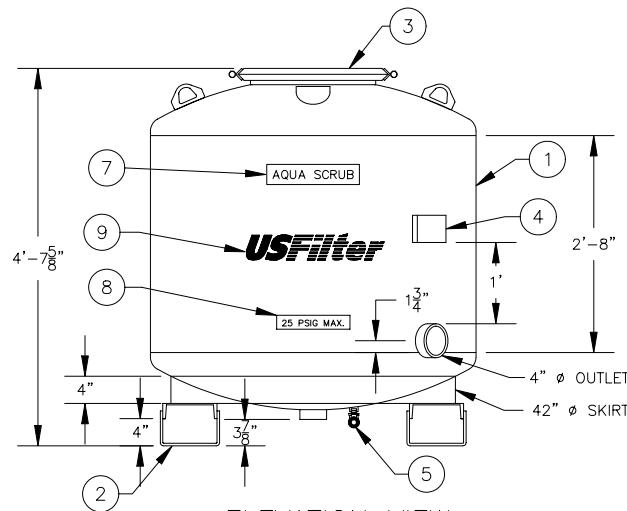

ELEVATION VIEW

NOTES:

- DESIGN DATA:**  
48" DIAMETER PRESSURE VESSEL-25 PSIG(MAX)  
@ 120°F-NOT ASME CODE STAMPED FOR AQUA USE ONLY  
600 CFM  
1000 LBS. ACTIVATED CARBON
- MATERIAL:**  
HEADS - SA 36-HR  
SHELL - SA 36-HR  
SKID - SA 36-HR
- SURFACE PREPARATION:**  
**INTERIOR:**  
SANDBLAST: SSPC-SP-5 WHITE METAL  
ABRASIVE: GARNET OR GRIT - PROFILE: 1.5-2 MILS  
COATING: 3M BRAND SCOTCHKOTE 134  
THICKNESS: 10-15 DFMT - COLOR: GREEN  
**EXTERIOR:**  
SANDBLAST: SSPC-SP-10 NEAR WHITE METAL  
ABRASIVE: GARNET OR GRIT - PROFILE: 1.5-2 MILS  
PRIMER COAT: RUST PREVENTATIVE EPOXY PRIMER (CARBOLINE 893)  
THICKNESS: 4-6 DFMT - COLOR: RED  
FINISH COAT: HIGH BUILD POLYURETHANE (CARBOLINE 134HG)  
THICKNESS: 3-4 DFMT - COLOR: WHITE (FED. I.D.#17925)
- LIFTING REQUIREMENTS:**  
5200 LBS. MINIMUM RATING.  
EST. WEIGHTS:  
890 LBS. - EMPTY VESSEL  
1890 LBS. - WITH CARBON  
4280 LBS. - OPERATING

COMPANY CONFIDENTIAL  
THIS DOCUMENT AND ALL INFORMATION CONTAINED HEREIN ARE THE PROPERTY OF THE USFILTER AND/OR ITS AFFILIATES ("USF"). THE DESIGN CONCEPTS AND INFORMATION CONTAINED HEREIN ARE PROPRIETARY TO USF AND ARE SUBMITTED IN CONFIDENCE. THEY ARE NOT TRANSFERABLE AND MUST BE USED ONLY FOR THE PURPOSE FOR WHICH THE DOCUMENT IS EXPRESSLY LOANED. THEY MUST NOT BE DISCLOSED, REPRODUCED, LOANED OR USED IN ANY OTHER MANNER WITHOUT THE EXPRESS WRITTEN CONSENT OF USF. IN NO EVENT SHALL THEY BE USED IN ANY MANNER DETRIMENTAL TO THE INTEREST OF USF. ALL PATENT RIGHTS ARE RESERVED. UPON THE DEMAND OF USF, THIS DOCUMENT, ALONG WITH ALL COPIES AND EXTRACTS, AND ALL RELATED NOTES AND ANALYSES, MUST BE RETURNED TO USF OR DESTROYED, AS INSTRUCTED BY USF. ACCEPTANCE OF THE DELIVERY OF THIS DOCUMENT CONSTITUTES AGREEMENT TO THESE TERMS AND CONDITIONS.

DESIGNER	DATE
AJA	10-8-01
CHECKER	DATE
ENGINEER	DATE
MANAGER	DATE
FILE:	
SCALE: NONE	

TITLE		ASC1000 GENERAL ASSEMBLY		
CLIENT				
PROJECT		DRAWING ASC1000SHEET1.DWG		
SHEET		1 OF 3		
REV				



LIST OF COMPONENTS

ITEM	QTY	DESCRIPTION
1	1	TANK ASSEMBLY
2	1	SKID ASSEMBLY
3	1	MANWAY ASSEMBLY, 18" DIA.
4	1	PLATE, I.D. & SERIAL NUMBER
5	1	BRONZE BALL VALVE, 3/4"
6	1	DECAL, "FOR WATER USE ONLY", 2 1/2" x 4 1/4"
7	2	DECAL, "AQUA-SCRUB", WHITE MYLAR
8	2	DECAL, "25 PSIG MAX", WHITE MYLAR
9	2	DECAL, "USFILTER/WESTATES" WHITE MYLAR W/BUE LETTERS

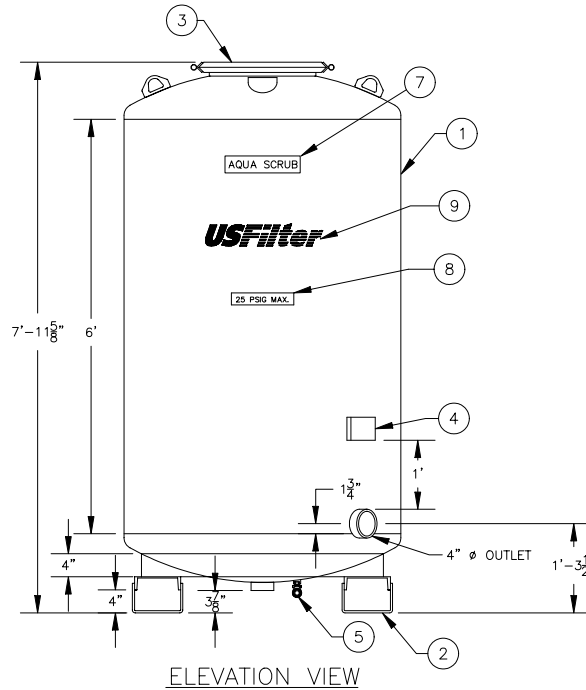
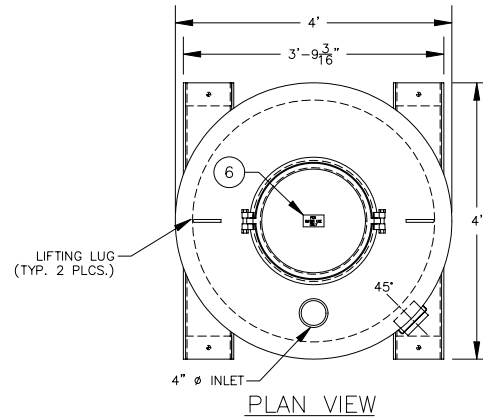

NOTES:

- DESIGN DATA:**  
48" DIAMETER PRESSURE VESSEL-25 PSIG (MAX)  
@ 120°F-NOT ASME CODE STAMPED FOR WATER USE ONLY  
50 GPM  
2000 LBS. ACTIVATED CARBON
- MATERIAL:**  
HEADS - SA 36-HR  
SHELL - SA 36-HR  
SKID - SA 36-HR
- SURFACE PREPARATION:**  
**INTERIOR:**  
SANDBLAST: SSPC-SP-5 WHITE METAL  
ABRASIVE: GARNET OR GRIT - PROFILE: 1.5-2 MILS  
COATING: 3M BRAND SCOTCHKOTE 134  
THICKNESS: 10-15 DFMT - COLOR: GREEN  
**EXTERIOR:**  
SANDBLAST: SSPC-SP-10 NEAR WHITE METAL  
ABRASIVE: GARNET OR GRIT - PROFILE: 1.5-2 MILS  
PRIMER COAT: RUST PREVENTATIVE EPOXY PRIMER (CARBOLINE 893)  
THICKNESS: 4-6 DFMT - COLOR: RED  
FINISH COAT: HIGH BUILD POLYURETHANE (CARBOLINE 134HG)  
THICKNESS: 3-4 DFMT - COLOR: WHITE (FED. I.D.#17925)
- LIFTING REQUIREMENTS:**  
5200 LBS. MINIMUM RATING.  
EST. WEIGHTS:  
1190 LBS. - EMPTY VESSEL  
3190 LBS. - WITH CARBON  
7317 LBS. - OPERATING

COMPANY CONFIDENTIAL  
THIS DOCUMENT AND ALL INFORMATION CONTAINED HEREIN ARE THE PROPERTY OF THE USFILTER AND/OR ITS AFFILIATES ("USF"). THE DESIGN CONCEPTS AND INFORMATION CONTAINED HEREIN ARE PROPRIETARY TO USF AND ARE SUBMITTED IN CONFIDENCE. THEY ARE NOT TRANSFERABLE AND MUST BE USED ONLY FOR THE PURPOSE FOR WHICH THE DOCUMENT IS EXPRESSLY LOANED. THEY MUST NOT BE DISCLOSED, REPRODUCED, LOANED OR USED IN ANY OTHER MANNER WITHOUT THE EXPRESS WRITTEN CONSENT OF USF. IN NO EVENT SHALL THEY BE USED IN ANY MANNER DETRIMENTAL TO THE INTEREST OF USF. ALL PATENT RIGHTS ARE RESERVED. UPON THE DEMAND OF USF, THIS DOCUMENT, ALONG WITH ALL COPIES AND EXTRACTS, AND ALL RELATED NOTES AND ANALYSES, MUST BE RETURNED TO USF OR DESTROYED, AS INSTRUCTED BY USF. ACCEPTANCE OF THE DELIVERY OF THIS DOCUMENT CONSTITUTES AGREEMENT TO THESE TERMS AND CONDITIONS.

DESIGNER	DATE
AJA	10-8-01
CHECKER	DATE
ENGINEER	DATE
MANAGER	DATE
FILE:	
SCALE: NONE	

TITLE		ASC2000 GENERAL ASSEMBLY		
CLIENT				
PROJECT		DRAWING		
SCALE: NONE		ASC2000SHEET1.DWG		
SHEET		1 OF 5		
REV				



USFILTER/WESTATES  
RED BLUFF, CA  
1-800-795-2664

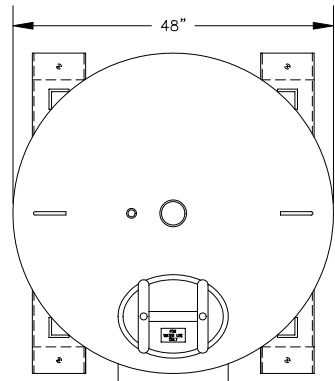

PLAN VIEW

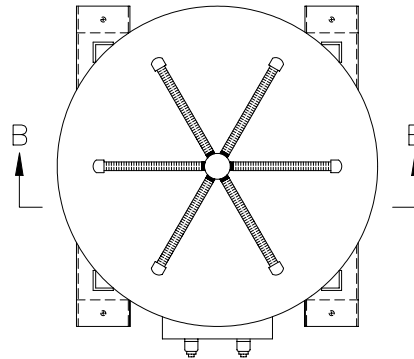

SECTION "A-A"

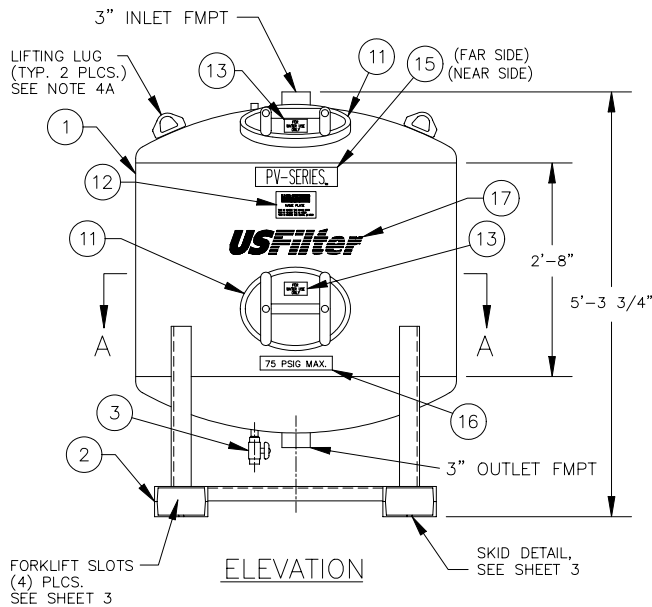

ELEVATION

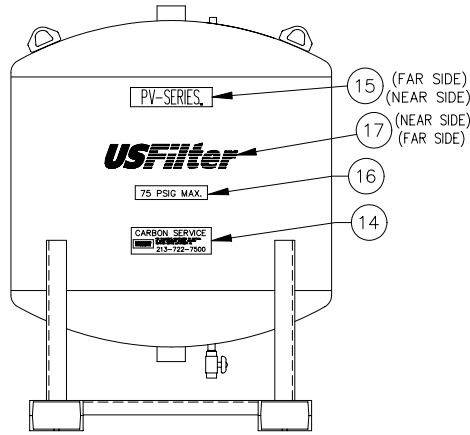

REAR ELEVATION

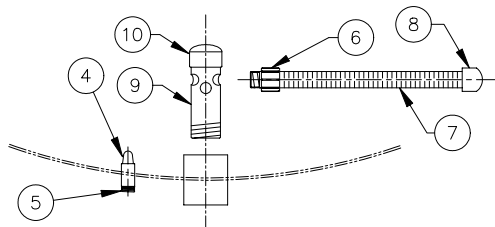

ENLARGED SECTION VIEW B-B  
UNDERDRAIN ASSEMBLY-(SEPARATED)

LIST OF COMPONENTS

ITEM	QTY	DESCRIPTION
1		TANK ASSEMBLY DWG. # PV1000SHEET2
2		SKID ASSEMBLY DWG. # PV1000SHEET3
3	1	BRONZE BALL VALVE, 3/4"
4	1	POLY SCREEN ORTHOS PART# N5 R-3/4", MPT
5	1	CLOSE NIPPLE, SCHD 40 304 SS, 3/4"
6	6	MALE ADAPTER, SCH 80 PVC, 1"
7	6	PIPE, SLOTTED SCH 80 PVC, 1" x 15" LG
8	6	CAP, SCH 80 PVC, SLIP, 1"
9	1	UNDERDRAIN HUB, 3" DIA x 10 1/2" LG, SCH 80 PVC
10	1	CAP, SCH 80 PVC, SLIP, 3"
11	2	MANWAY ASSEMBLY, 11" x 15"
12	1	PLATE, I.D. & SERIAL NUMBER
13	2	DECAL, "FOR WATER USE ONLY", 2 1/2" x 4 1/4"
14	1	DECAL, "CARBON SERVICE" WHITE MYLAR W/BUE LETTERS, 4" x 12"
15	2	DECAL, "PV-SERIES", WHITE MYLAR
16	2	DECAL, "75 PSIG MAX", WHITE MYLAR
17	2	DECAL, "USFILTER/WESTATES" WHITE MYLAR W/BUE LETTERS

NOTES:

- DESIGN DATA:**  
 48" DIAMETER PRESSURE VESSEL-75 PSIG(MAX)  
 @ 150°F-NOT ASME CODE STAMPED  
 FOR WATER USE ONLY  
 MAXIMUM FLOW RATE: 50 GPM  
 MAXIMUM CARBON CAPACITY: 1000 LBS. ACTIVATED CARBON
- MATERIAL:**  
 HEADS: STD. F & D NON CODE 3/16" THICKNESS C.S.  
 SHELL: 3/16" THK. 48" OD x 32" LONG C.S.  
 SKID: SA 36-HR
- SURFACE PREPARATION:**  
**INTERIOR:**  
 SANDBLAST: SSPC-SP-5 WHITE METAL  
 ABRASIVE: GARNET OR GRIT - PROFILE: 1.5-2 MILS  
 COATING: 3M BRAND SCOTCHKOTE 134  
 THICKNESS: 10-15 DFMT - COLOR: GREEN  
**EXTERIOR:**  
 SANDBLAST: SSPC-SP-10 NEAR WHITE METAL  
 ABRASIVE: GARNET OR GRIT - PROFILE: 1.5-2 MILS  
 PRIMER COAT: RUST PREVENTATIVE EPOXY PRIMER (CARBOLINE 893)  
 THICKNESS: 4-6 DFMT - COLOR: RED  
 FINISH COAT: HIGH BUILD POLYURETHANE (CARBOLINE 134HG)  
 THICKNESS: 3-4 DFMT - COLOR: BLUE (FED. I.D.#15052)
- LIFTING REQUIREMENTS:**  
 3,700 LBS. MINIMUM RATING.  
 EST. WEIGHTS:  
 910 LBS. - EMPTY VESSEL  
 1910 LBS. - WITH CARBON  
 4300 LBS. - OPERATING

COMPANY CONFIDENTIAL  
 THIS DOCUMENT AND ALL INFORMATION CONTAINED HEREIN ARE THE PROPERTY OF THE USFILTER AND/OR ITS AFFILIATES ("USF"). THE DESIGN CONCEPTS AND INFORMATION CONTAINED HEREIN ARE PROPRIETARY TO USF AND ARE SUBMITTED IN CONFIDENCE. THEY ARE NOT TRANSFERABLE AND MUST BE USED ONLY FOR THE PURPOSE FOR WHICH THE DOCUMENT IS EXPRESSLY LOANED. THEY MUST NOT BE DISCLOSED, REPRODUCED, LOANED OR USED IN ANY OTHER MANNER WITHOUT THE EXPRESS WRITTEN CONSENT OF USF. IN NO EVENT SHALL THEY BE USED IN ANY MANNER DETRIMENTAL TO THE INTEREST OF USF. ALL PATENT RIGHTS ARE RESERVED. UPON THE DEMAND OF USF, THIS DOCUMENT, ALONG WITH ALL COPIES AND EXTRACTS, AND ALL RELATED NOTES AND ANALYSES, MUST BE RETURNED TO USF OR DESTROYED, AS INSTRUCTED BY USF. ACCEPTANCE OF THE DELIVERY OF THIS DOCUMENT CONSTITUTES AGREEMENT TO THESE TERMS AND CONDITIONS.

DESIGNER	DATE
AJA	9-11-01
CHECKER	DATE
ENGINEER	DATE
MANAGER	DATE
FILE:	
SCALE: NONE	

TITLE		PV1000 GENERAL ASSEMBLY	
CLIENT			
PROJECT		DRAWING PV1000SHEET1	
SHEET		1 OF 5	
REV			





LIST OF COMPONENTS

ITEM	QTY	DESCRIPTION
1		TANK ASSEMBLY DWG. # PV2000SHEET2
2		SKID ASSEMBLY DWG. # PV2000SHEET3
3	1	BRONZE BALL VALVE, 3/4"
4	1	POLY SCREEN ORTHOS PART# N5 R-3/4", MPT
5	1	CLOSE NIPPLE, SCHD 40 304 SS, 3/4"
6	6	MALE ADAPTER, SCH 80 PVC, 1"
7	6	PIPE, SLOTTED SCH 80 PVC, 1" x 15" LG
8	6	CAP, SCH 80 PVC, SLIP, 1"
9	1	UNDERDRAIN HUB, 3" DIA x 10 1/2" LG, SCH 80 PVC
10	1	CAP, SCH 80 PVC, SLIP, 3"
11	2	MANWAY ASSEMBLY, 11" x 15"
12	1	PLATE, I.D. & SERIAL NUMBER
13	2	DECAL, "FOR WATER USE ONLY", 2 1/2" x 4 1/4"
14	1	DECAL, "CARBON SERVICE" WHITE MYLAR W/BUE LETTERS, 4" x 12"
15	2	DECAL, "PV-SERIES", WHITE MYLAR
16	2	DECAL, "75 PSIG MAX", WHITE MYLAR
17	2	DECAL, "USFILTER/WESTATES" WHITE MYLAR W/BUE LETTERS

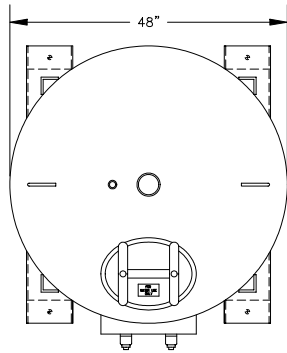

PLAN VIEW

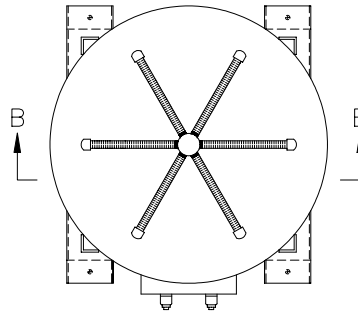

SECTION "A-A"

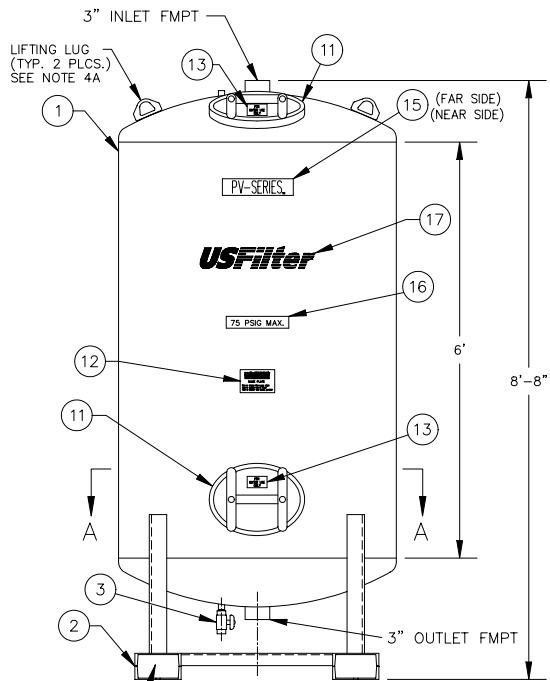

ELEVATION

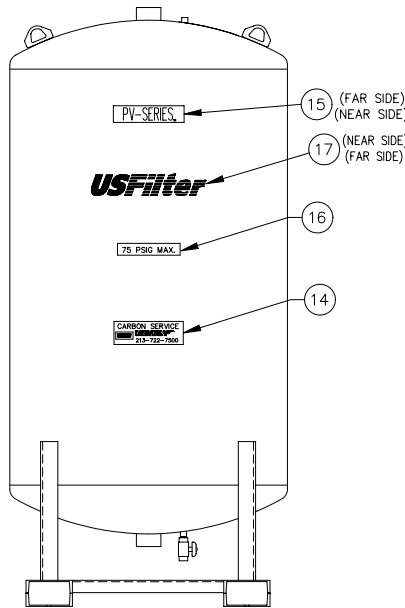

REAR ELEVATION

FORKLIFT SLOTS (4) PLCS. SEE SHEET 3

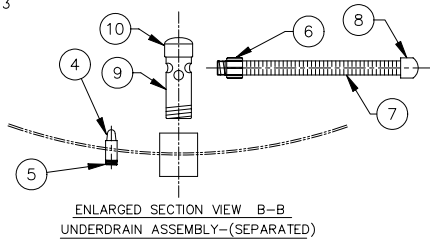

ENLARGED SECTION VIEW B-B UNDERDRAIN ASSEMBLY--(SEPARATED)

NOTES:

- DESIGN DATA:**  
48" DIAMETER PRESSURE VESSEL-75 PSIG(MAX)  
@ 150°F--NOT ASME CODE STAMPED FOR WATER USE ONLY  
MAXIMUM FLOW RATE: 100 GPM  
MAXIMUM CARBON CAPACITY: 2000 LBS. ACTIVATED CARBON
- MATERIAL:**  
HEADS: STD. F & D NON CODE 3/16" THICKNESS C.S.  
SHELL: 3/16" THK. 48" OD x 72" LONG C.S.  
SKID: SA 36-HR
- SURFACE PREPARATION:**  
**INTERIOR:**  
SANDBLAST: SSPC-SP-5 WHITE METAL  
ABRASIVE: GARNET OR GRIT - PROFILE: 1.5-2 MILS  
COATING: 3M BRAND SCOTCHKOTE 134  
THICKNESS: 10-15 DFMT - COLOR: GREEN  
**EXTERIOR:**  
SANDBLAST: SSPC-SP-10 NEAR WHITE METAL  
ABRASIVE: GARNET OR GRIT - PROFILE: 1.5-2 MILS  
PRIMER COAT: RUST PREVENTATIVE EPOXY PRIMER (CARBOLINE 893)  
THICKNESS: 4-6 DFMT - COLOR: RED  
FINISH COAT: HIGH BUILD POLYURETHANE (CARBOLINE 134HG)  
THICKNESS: 3-4 DFMT - COLOR: BLUE (FED. I.D.#15052)
- LIFTING REQUIREMENTS:**  
5,200 LBS. MINIMUM RATING.  
EST. WEIGHTS:  
1190 LBS. - EMPTY VESSEL  
3190 LBS. - WITH CARBON  
7717 LBS. - OPERATING

COMPANY CONFIDENTIAL THIS DOCUMENT AND ALL INFORMATION CONTAINED HEREIN ARE THE PROPERTY OF THE USFILTER AND/OR ITS AFFILIATES ("USF"). THE DESIGN CONCEPTS AND INFORMATION CONTAINED HEREIN ARE PROPRIETARY TO USF AND ARE SUBMITTED IN CONFIDENCE. THEY ARE NOT TRANSFERABLE AND MUST BE USED ONLY FOR THE PURPOSE FOR WHICH THE DOCUMENT IS EXPRESSLY LOANED. THEY MUST NOT BE DISCLOSED, REPRODUCED, LOANED OR USED IN ANY OTHER MANNER WITHOUT THE EXPRESS WRITTEN CONSENT OF USF. IN NO EVENT SHALL THEY BE USED IN ANY MANNER DETRIMENTAL TO THE INTEREST OF USF. ALL PATENT RIGHTS ARE RESERVED. UPON THE DEMAND OF USF, THIS DOCUMENT, ALONG WITH ALL COPIES AND EXTRACTS, AND ALL RELATED NOTES AND ANALYSES, MUST BE RETURNED TO USF OR DESTROYED, AS INSTRUCTED BY USF. ACCEPTANCE OF THE DELIVERY OF THIS DOCUMENT CONSTITUTES AGREEMENT TO THESE TERMS AND CONDITIONS.		DESIGNER AJA	DATE 9-11-01	TITLE PV2000 GENERAL ASSEMBLY
	CHECKER	DATE		
	ENGINEER	DATE	CLIENT	
	MANAGER	DATE		
FILE:			USFILTER/WESTATES RED BLUFF, CA 1-800-795-2664	
SCALE: NONE				PROJECT DRAWING SHEET PV2000SHEET1 1 OF 5 REV

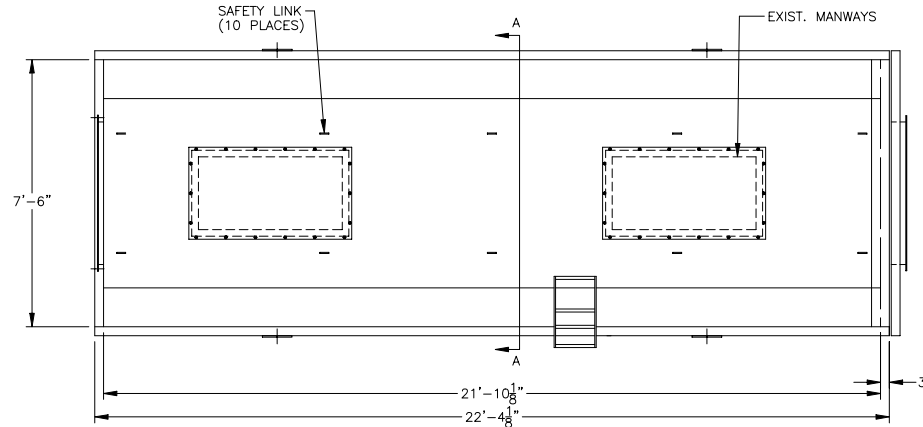

PLAN VIEW  
SCALE: 1"=2'-0"

NOTES:

- DESIGN DATA:  
14 INCHES W.G.
- MATERIAL:  
CARBON STEEL
- SURFACE PREPARATION:  
(A) PRIMER: (2) PART EPOXY PRIMER  
(B) FINISH: POLYURETHANE, BLUE
- APPROXIMATE WEIGHTS:  
EMPTY: (NO CARBON)  
ROOF: ..... 1,400 LBS  
BOX: ..... 8,100 LBS  
TOTAL: ..... 9,500 LBS

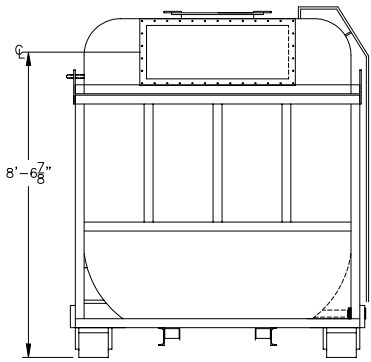

END VIEW

4-1/2" Ø HOLE  
INSTALL ON BOTH SIDES  
OF WALL

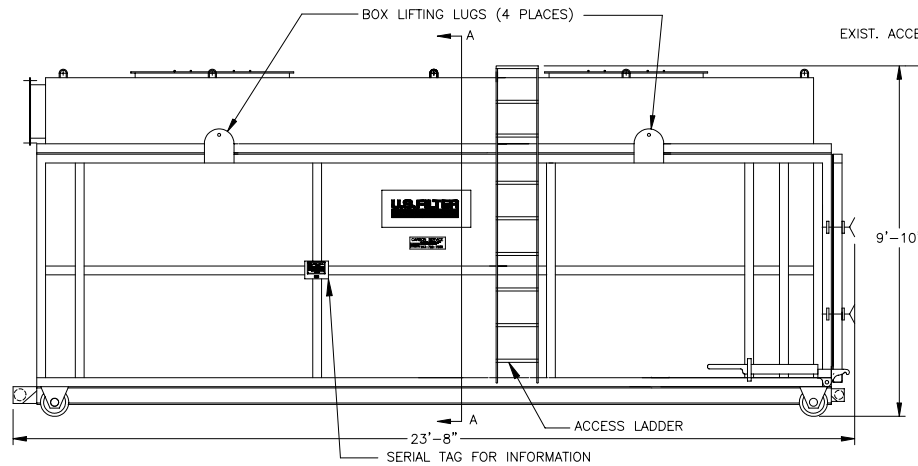

SIDE VIEW

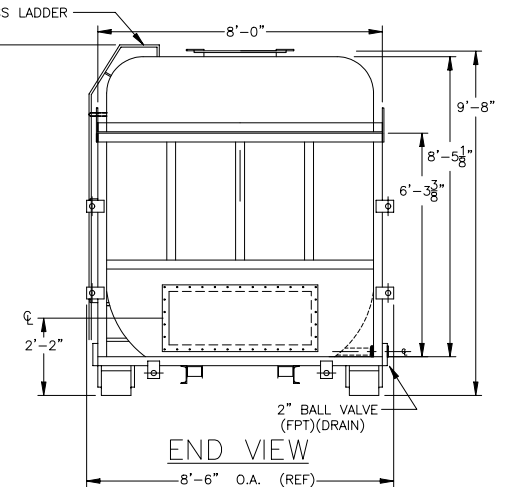

END VIEW

ELEVATION VIEWS

<p>COMPANY CONFIDENTIAL</p> <p>THIS DOCUMENT AND ALL INFORMATION CONTAINED HEREIN ARE THE PROPERTY OF THE USFILTER AND/OR ITS AFFILIATES ("USF"). THE DESIGN CONCEPTS AND INFORMATION CONTAINED HEREIN ARE PROPRIETARY TO USF AND ARE SUBMITTED IN CONFIDENCE. THEY ARE NOT TRANSFERABLE AND MUST BE USED ONLY FOR THE PURPOSE FOR WHICH THE DOCUMENT IS EXPRESSLY LOANED. THEY MUST NOT BE DISCLOSED, REPRODUCED, LOANED OR USED IN ANY OTHER MANNER WITHOUT THE EXPRESS WRITTEN CONSENT OF USF. IN NO EVENT SHALL THEY BE USED IN ANY MANNER DETRIMENTAL TO THE INTEREST OF USF. ALL PATENT RIGHTS ARE RESERVED. UPON THE DEMAND OF USF, THIS DOCUMENT, ALONG WITH ALL COPIES AND EXTRACTS, AND ALL RELATED NOTES AND ANALYSES, MUST BE RETURNED TO USF OR DESTROYED, AS INSTRUCTED BY USF. ACCEPTANCE OF THE DELIVERY OF THIS DOCUMENT CONSTITUTES AGREEMENT TO THESE TERMS AND CONDITIONS.</p>	DESIGNER	DATE	TITLE RB20 GENERAL ASSEMBLY			
	LLR	5-21-01	CHECKER	DATE	CLIENT	
	ENGINEER	DATE	 USFILTER/WESTATES RED BLUFF, CA 1-800-795-2664			
	MANAGER	DATE				
	FILE:	PROJECT		DRAWING	SHEET	REV
SCALE: NONE	RB20 OS A SIZE.DWG		1 OF 1			

NOTES:

1. CARBON CAPACITY 12000 LB
2. FLOW RATE 8000CFM MAX.
3. MAX. PRESSURE 28 " W.C. / 2" W.C. VACUUM
4. EMPTY WEIGHT 9500 LB.
5. INLET/ OUT LET 12"X36".
6. MAX TEMPERATURE 140°F

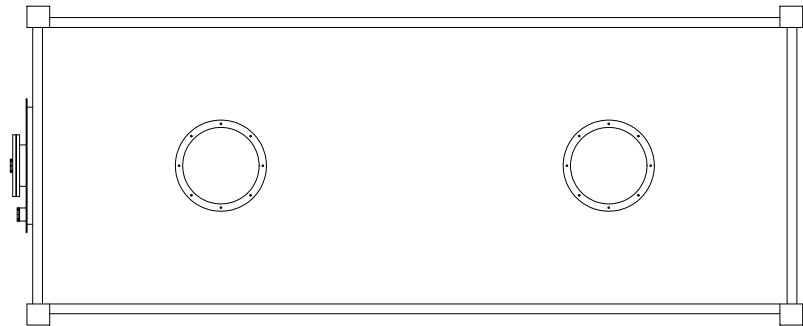

TOP VIEW

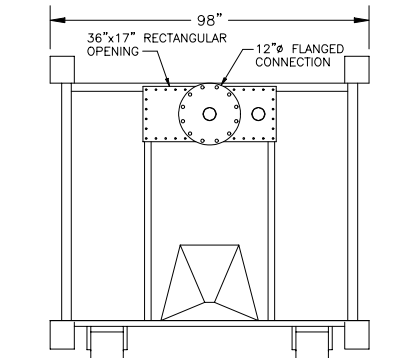

END VIEW

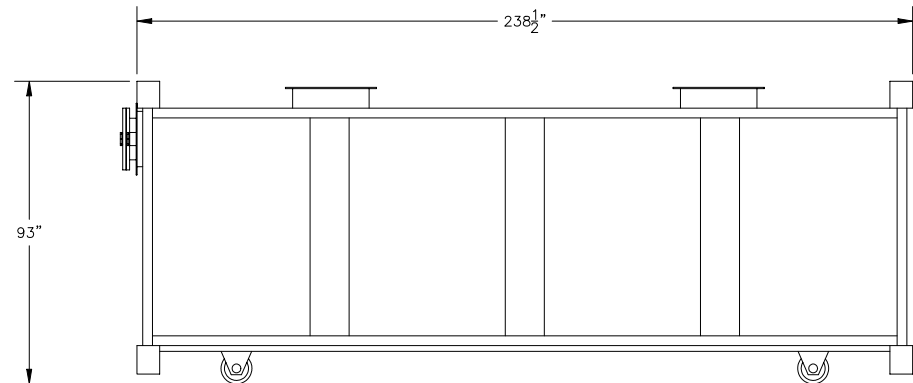

SIDE VIEW

COMPANY CONFIDENTIAL THIS DOCUMENT AND ALL INFORMATION CONTAINED HEREIN ARE THE PROPERTY OF THE USFILTER AND/OR ITS AFFILIATES ("USF"). THE DESIGN CONCEPTS AND INFORMATION CONTAINED HEREIN ARE PROPRIETARY TO USF AND ARE SUBMITTED IN CONFIDENCE. THEY ARE NOT TRANSFERABLE AND MUST BE USED ONLY FOR THE PURPOSE FOR WHICH THE DOCUMENT IS EXPRESSLY LOANED. THEY MUST NOT BE DISCLOSED, REPRODUCED, LOANED OR USED IN ANY OTHER MANNER WITHOUT THE EXPRESS WRITTEN CONSENT OF USF. IN NO EVENT SHALL THEY BE USED IN ANY MANNER DETRIMENTAL TO THE INTEREST OF USF. ALL PATENT RIGHTS ARE RESERVED. UPON THE DEMAND OF USF, THIS DOCUMENT, ALONG WITH ALL COPIES AND EXTRACTS, AND ALL RELATED NOTES AND ANALYSES, MUST BE RETURNED TO USF OR DESTROYED, AS INSTRUCTED BY USF. ACCEPTANCE OF THE DELIVERY OF THIS DOCUMENT CONSTITUTES AGREEMENT TO THESE TERMS AND CONDITIONS.	DESIGNER	DATE	TITLE RB10 OS GENERAL ASSEMBLY					
	LLR	5-9-01						
	CHECKER	DATE	CLIENT					
	ENGINEER	DATE						
	MANAGER	DATE	 USFILTER/WESTATES RED BLUFF, CA 1-800-795-2664					
FILE:		PROJECT				DRAWING	SHEET	REV
SCALE: NONE		RB10				OSGENASSY	OF	

RB12HV

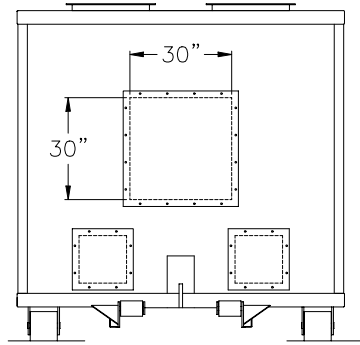

LEFT END VIEW

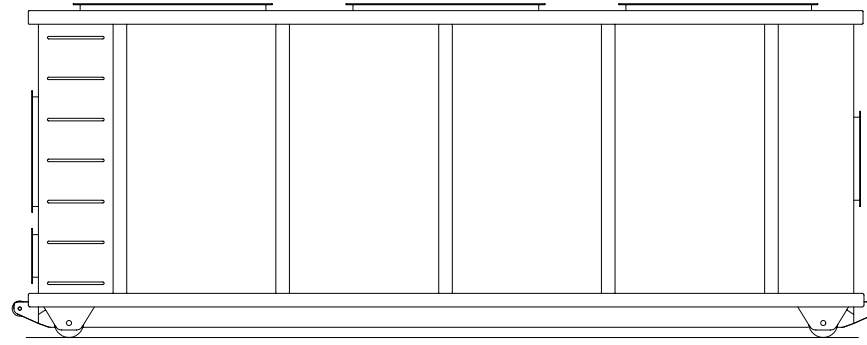

SIDE VIEW

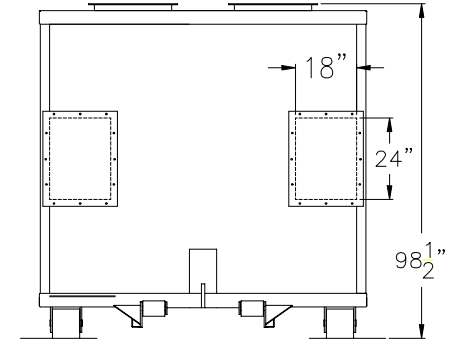

RIGHT END VIEW

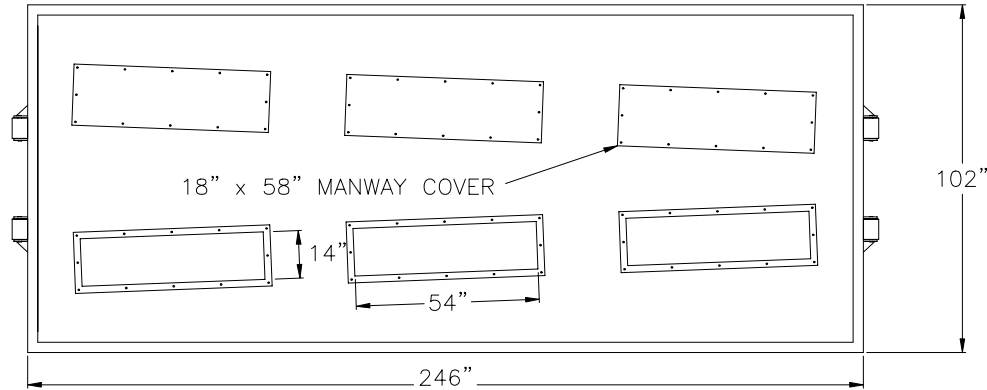

PLAN VIEW

SPECIFICATIONS:

1. 20,000 SCFM MAX FLOW RATE
2. 12,000 LBS ACTIVATED CARBON
3. 30" X 30" INLET, 2-18" X 24" OUTLETS.
4. PRIMED AND PAINTED
5. RIBBED CARBON STEEL CONSTRUCTION
6. 8" GROUND ROLLERS FOR HANDLING EASE
7. 18" x 58" MANWAYS
8. BOXES TO BE GROUNDED BY BRAIDED COPPER #4
9. SHIPPING WEIGHT (WITH CARBON) APPROX.= 22,000 LB
10. PROVIDE SAMPLE PORTS 1/2" BALL VALVE WITH HOSE FITTING.

COMPANY CONFIDENTIAL THIS DOCUMENT AND ALL INFORMATION CONTAINED HEREIN ARE THE PROPERTY OF THE USFILTER AND/OR ITS AFFILIATES ("USF"). THE DESIGN CONCEPTS AND INFORMATION CONTAINED HEREIN ARE PROPRIETARY TO USF AND ARE SUBMITTED IN CONFIDENCE. THEY ARE NOT TRANSFERABLE AND MUST BE USED ONLY FOR THE PURPOSE FOR WHICH THE DOCUMENT IS EXPRESSLY LOANED. THEY MUST NOT BE DISCLOSED, REPRODUCED, LOANED OR USED IN ANY OTHER MANNER WITHOUT THE EXPRESS WRITTEN CONSENT OF USF. IN NO EVENT SHALL THEY BE USED IN ANY MANNER DETRIMENTAL TO THE INTEREST OF USF. ALL PATENT RIGHTS ARE RESERVED. UPON THE DEMAND OF USF, THIS DOCUMENT, ALONG WITH ALL COPIES AND EXTRACTS, AND ALL RELATED NOTES AND ANALYSES, MUST BE RETURNED TO USF OR DESTROYED, AS INSTRUCTED BY USF. ACCEPTANCE OF THE DELIVERY OF THIS DOCUMENT CONSTITUTES AGREEMENT TO THESE TERMS AND CONDITIONS.	DESIGNER	DATE	TITLE RB12HV GENERAL ASSEMBLY		
	LLR	4-8-01			
	CHECKER	DATE	CLIENT		
	ENGINEER	DATE			
MANAGER	DATE	USFILTER/WESTATES RED BLUFF, CA 1-800-795-2664			
FILE:					PROJECT
SCALE: NONE			RB12HVGENASSY	OF	

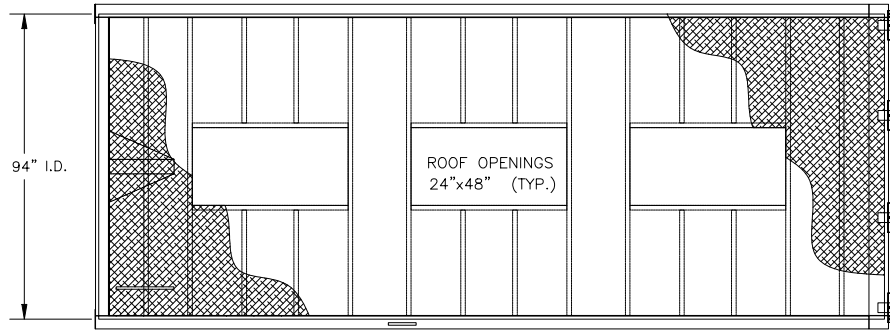

PLAN VIEW

NOTES :

1. CONTINUOUS WELDED CONSTRUCTION.
2. EPOXY PRIMED INTERIOR AND EXTERIOR PRIMED AND FINISHED WITH POLYURETHANE.
3. TOP HINGED TAILGATE.
4. VESSEL WEIGHT: 10,500 LBS.
5. VESSEL WEIGHT W/ CARBON: 30,500 LBS.
7. FLOWRATE 12,000 CFM MAX.

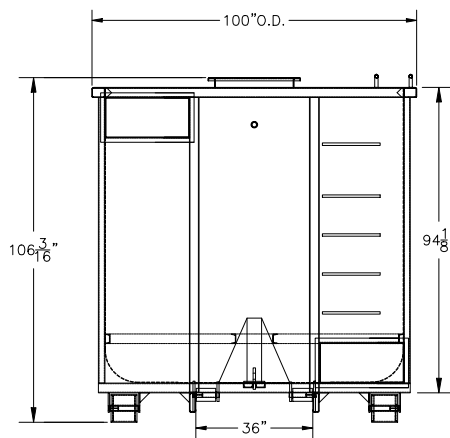

FRONT VIEW

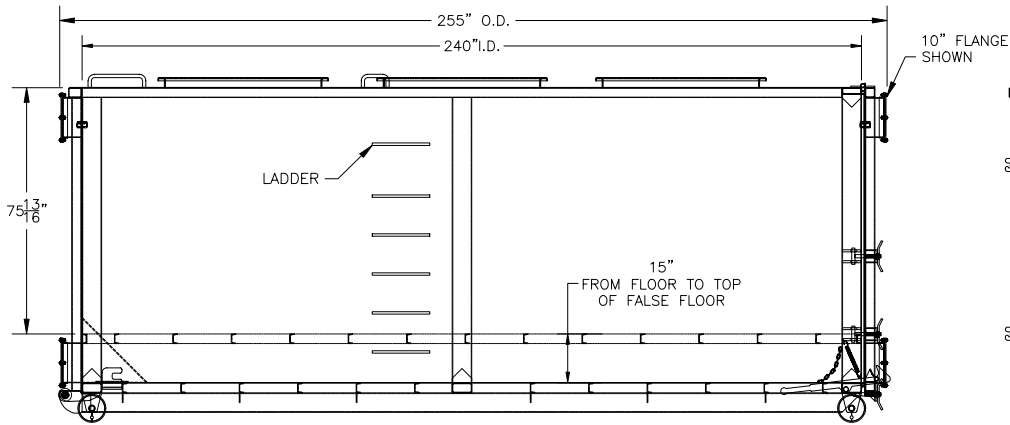

SIDE VIEW

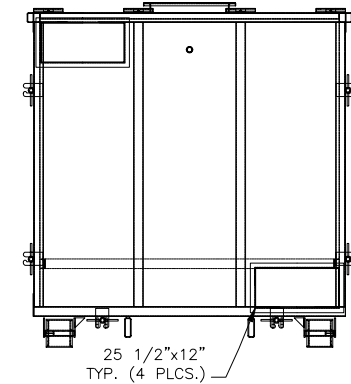

REAR VIEW

COMPANY CONFIDENTIAL  
THIS DOCUMENT AND ALL INFORMATION CONTAINED HEREIN ARE THE PROPERTY OF THE USFILTER AND/OR ITS AFFILIATES ("USF"). THE DESIGN CONCEPTS AND INFORMATION CONTAINED HEREIN ARE PROPRIETARY TO USF AND ARE SUBMITTED IN CONFIDENCE. THEY ARE NOT TRANSFERABLE AND MUST BE USED ONLY FOR THE PURPOSE FOR WHICH THE DOCUMENT IS EXPRESSLY LOANED. THEY MUST NOT BE DISCLOSED, REPRODUCED, LOANED OR USED IN ANY OTHER MANNER WITHOUT THE EXPRESS WRITTEN CONSENT OF USF. IN NO EVENT SHALL THEY BE USED IN ANY MANNER DETRIMENTAL TO THE INTEREST OF USF. ALL PATENT RIGHTS ARE RESERVED. UPON THE DEMAND OF USF, THIS DOCUMENT, ALONG WITH ALL COPIES AND EXTRACTS, AND ALL RELATED NOTES AND ANALYSES, MUST BE RETURNED TO USF OR DESTROYED, AS INSTRUCTED BY USF. ACCEPTANCE OF THE DELIVERY OF THIS DOCUMENT CONSTITUTES AGREEMENT TO THESE TERMS AND CONDITIONS.

DESIGNER	DATE
ESP	4-9-01
CHECKER	DATE
LLR	4-9-01
ENGINEER	DATE
MANAGER	DATE
FILE:	
SCALE: NONE	

TITLE		RB20 GENERAL ASSEMBLY	
CLIENT			
PROJECT		DRAWING	SHEET
		RB20 8X11	OF
USFILTER		USFILTER/WESTATES RED BLUFF, CA 1-800-795-2664	
SCALE: NONE			REV

*New drawing*

ITEM	QTY	DESCRIPTION	ITEM	QTY	DESCRIPTION	ITEM	QTY	DESCRIPTION
1	1	BODY & FRAME SEE DRG. #2220A (BODY MAT-188/.203)	24	1	2" MANIFOLD ALUM. PIPE SEE DRWG. #2220C	43	4	TRUCK LITE STOP/TAI/TURN RED LIGHTS
2	4	KNAPPCO LM20 DOMES W/ BUNA-N GASKETS - HINGE TO STREETSIDE	25	4	4" ULTRAFLO VALVES-MODEL 400 W/ NITRILE SEATS	44	6	TRUCK LITE MARKER LIGHTS (2) RED & (4) AMBER
3	11	2" ULTRAFLO VALVES- (7) IN WATER LINE & (4) IN DEWATER LINE- MODEL 400 W/ NITRILE SEATS	26	4	4" MALE ADAPTORS & CAPS ON END OF 4" LOAD LINE & 4" DEWATER LINE	45	1	TRUCK LITE I. D. CLUSTER
4	2	3" ULTRAFLO VALVES- MODEL 400 W/NITRILE SEATS	27	1	4" ALUM. SCH. 40 PIPE DEWATER LINE SEE VIEW B - B	46	3	INTERNAL RINGS - 3" X 3/8" FLAT BARS ON EDGE. BARS ARE PERPENDICULAR TO SHELL
5	1	2" BAYCO PRESSURE RELIEF VALVE SET AR 15 P.S.I	28	1	LANDING GEAR- 2 SPEED-S/S CRANK #LPR-30-444	47	2	SANITARY BULKHEADS- 0.250" ALUM.
6	1	3" ALUM. TOP AIR PIPE	29	2	SUSPENSION- HENDRICKSON-TURNER HT-230-17-004	48	1	TOOL BOX- 24" H. X 36" L. X 24" DP. - STREETSIDE SEE DRWG. #2220B
7	1	3" COUPLER & PLUG STREETSIDE	30	2	AXLES- DANA 5" RD.- 1/2" WALL- 71 1/2" TRACK	49	4	2" N.P.T. NIPPLES INSIDE TANK -EXTEND INTO TANK 3 TO 4"
8	1	3" MALE ADAPTOR DUMMY CURBSIDE			W/CHICAGO RAWHIDE OIL SEALS	50	1	ROCKWELL WABCO 4S/2M ABS KIT W/ STOP LIGHT CONTROL.
9	1	HOSE HOOK- ADJUSTABLE	4	5 1/2"	GUNITITE AUTOMATIC SLACKS	51	1	BETTS PS-1 DOCUMENT HOLDER
10	2	3" KNAPPCO SWING CHECK VALVES	4	OUTBOARD CENTRIFUSE DRUMS- ALUM. HUBS	52	4	PLACARD HOLDERS- SLIDE IN STYLE- LOCATE (1) EACH END AND (1) EACH SIDE AT CENTER.	
11	2	4" STL. STEEL LONG RADIUS WELD 90° ELBOWS	4	30/30 COMBO MGM BRAKE CHAMBERS	53	1	WIRING HARNESS KIT W/ 7-WAY RECEPTACLE USA #602001	
12	1	2" MALE ADAPTOR & CAP AT END OF 2" WATER LINE	31	8	WHEELS- ALCOA ALUM.- 8.25 X 24.5	54	4	BEALL MUD FLAPS
13	8	2" VICTAULIC COUPLINGS W/ BUNA-N GASKETS	32	8	TIRES- 285/75R24.5 BRIDGESTONE R-194	55	-	PAINT STEEL PARTS WHEELABRATOR BLUE PAINTONE MATCHING SYSTEM #286,C 100,M 60, K 6
14	-	2" SCH. 40 ALUM. PIPE WATER LINE	33	2	ALUM. LIGHT HOUSINGS PER STD.- 605			
15	14	4" VICTAULIC COUPLINGS W/ BUNA-N GASKETS	34	2	TOE RAILS W/ 1" ALUM. PIPE FULL LENGTH			
16	-	4" SCH. 40 ALUM. PIPE	35	-	NON-SLIP PAINT BETWEEN TOE RAILS FULL LENGTH			
17	1	4" TOP LOAD LINE TO ENTER EACH OF 3-COMPTS. AT TOP CURBSIDE (SEE DRWG. #2220C)	36	1	ALUM. LADDER W/ 1" PIPE & 4 3/4" GRIP STRUT STEPS	56	1	3" VICTAULIC COUPLING W/ BUNA-N GASKETS
18	4	12" BOTTOM DROP ASSY. SEE DRWG. #2220D			11 3/4" WIDE GRIPSTRUT PIECES			
19	4	5" ULTRAFLO VALVES W/NITRILE SEATS	38	4	HOSE TUBE- 7" X 20'-0", 2 EA. SIDE-DOORS EA. END			
20	4	5" X 5" PENTRON TEES W/OUT DOORS - W/ VIC. ENDS	39	4	AIR PRESSURE GAUGES (2) 1N (2) ALUM. BOXES W/ LIGHT- 3 1/2" DIA. LIQUID FILLED. 0 TO 30 P.S.I.(TANK & LINE)			
21	7	5" VICTAULIC COUPLERS W/ BUNA-N GASKETS	40	1	KINGPIN PLATE PER STD.- 419			
22	-	5" SCH 40 DISCHARGE PIPE TO REAR UNDER AXLE	41	2	ALUM. FRONT FENDERS W/ RADIUS			
23	2	5" X 4" REDUCERS W/ (2) 4" MALE ADAPTORS & CAPS (1) EACH FRONT AND REAR ON DISCHARGE LINE.	42	2	ALUM. TANDEM FENDERS			

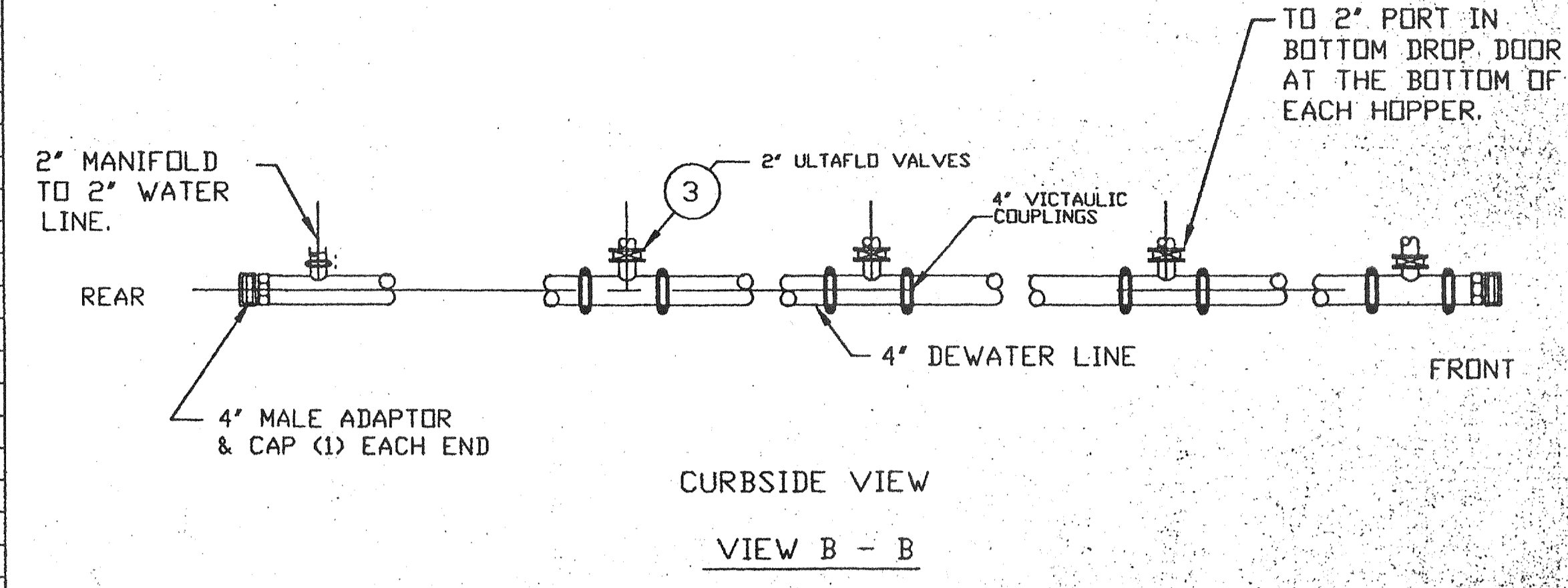

NOTE: FRONT & REAR 4" LOAD LINE INLETS ARE LOCATED ON THE SAME CENTERLINES AS THE FRONT & REAR 2" WATER LINE INLETS SEE DRWG. #2220C.

NOTE: USE 4" ALUM. SCH. 40 WELD S.R. WELD ELBOWS & TEES IN LOAD LINE.

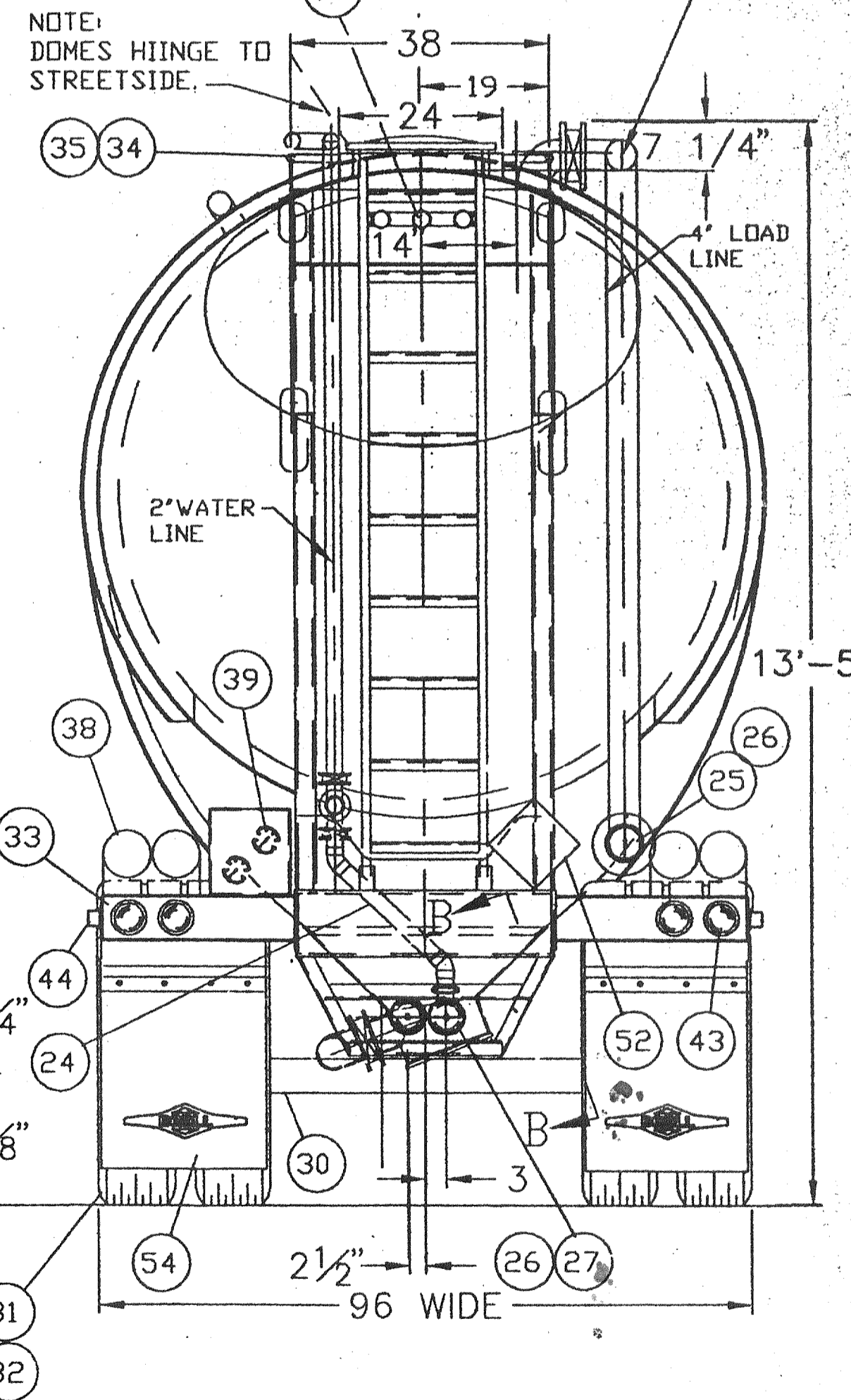
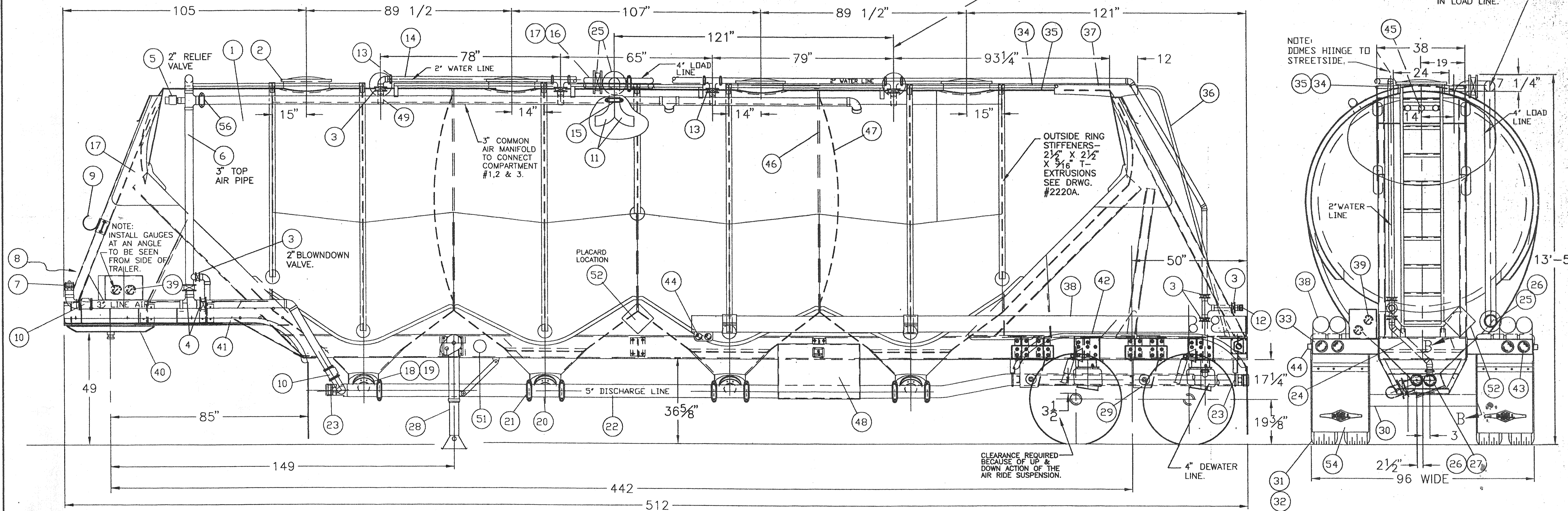

125° MAXIMUM TEMPERATURE

CUSTOMER APPROVAL  
DATE: \_\_\_\_\_  
BY: \_\_\_\_\_

NOTE: GRIND ALL INTERIOR BUTT WELDS SMOOTH IN PREPARATION FOR A LINER.

- (50) ABS KIT
- (53) WIRING HARNESS KIT
- (55) PAINT

DOT SPECIFICATION: N/A		SERIAL NUMBER: PS27472 & PS27473		<b>Beall Trailers of Oregon, Inc.</b>	
THIS DOCUMENT CONTAINS PROPRIETARY INFORMATION BELONGING TO BEALL TRAILERS, INC. AND SUCH INFORMATION MAY NOT BE DISCLOSED TO OTHERS, REPRODUCED, COPIED OR USED WITHOUT WRITTEN AUTHORITY FROM BEALL TRAILERS, INC.				WHEELABRATOR CLEAN AIR SYSTEMS	
F.O. #27472 & 27473-95				SCALE: 1:20	DRAWN BY: LA
TITLE: 1800 CU. FT. ALUMINUM PNEUMATIC SEMI				APPROVED BY: B91	
THRU CHANGE ORDER #2		LA REFERENCE	DATE: 10-25-95	DRAWING NUMBER: 2220	
DATE	SYM	REVISION RECORD		BY	

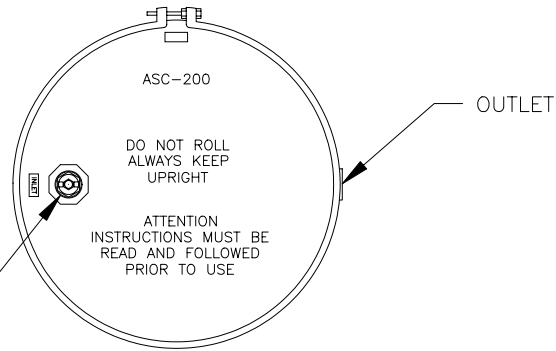

PLAN VIEW

FITTING (TRI SURE)  
2" FNPT

DO NOT ROLL  
ALWAYS KEEP  
UPRIGHT

ATTENTION  
INSTRUCTIONS MUST BE  
READ AND FOLLOWED  
PRIOR TO USE

NOTES:

- CARBON:  
AS REQUIRED.
- MATERIALS OF CONSTRUCTION:  
VESSEL: .....CARBON STEEL  
EXTERNAL COATING: .....HIGH GLOSS PAINT, WESTATES BLUE  
INTERNAL COATING: .....CURED EPOXY  
INTERNAL DISTRIBUTION: .....PVC
- SPECIFICATIONS:  
FLOW \* - CFM (MAX): ..... 100  
PRESSURE - PSIG (MAX): ..... 10  
TEMPERATURE - DEG F (MAX): ..... 140  
CARBON FILL VOLUME - CU FT: ..... 6.9  
CROSS SECTION - SQ FT: ..... 2.8  
SHIPPING WEIGHT - LBS: (APPROX,) ..... 250  
OPERATING WEIGHT - LBS: (APPROX,) ..... 500

\* NOTE: ACTUAL DESIGN SHOULD BE BASED ON SUPERFICIAL BED VELOCITY (SBV) AS REQUIRED FOR SPECIFIC CONTAMINANTS.

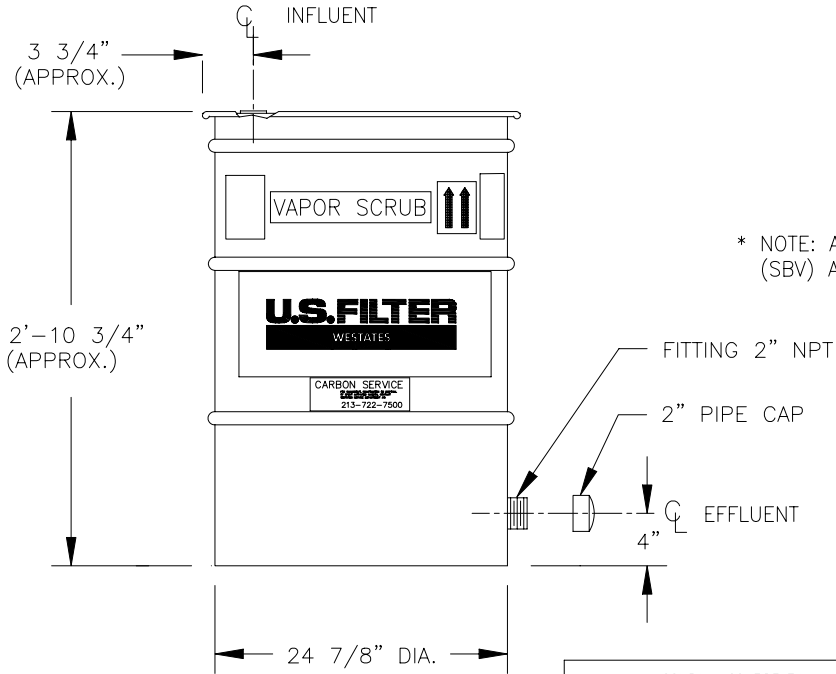

PLAN VIEW

COMPANY CONFIDENTIAL  
THIS DOCUMENT AND ALL INFORMATION CONTAINED HEREIN ARE THE PROPERTY OF THE USFILTER AND/OR ITS AFFILIATES ("USF"). THE DESIGN CONCEPTS AND INFORMATION CONTAINED HEREIN ARE PROPRIETARY TO USF AND ARE SUBMITTED IN CONFIDENCE. THEY ARE NOT TRANSFERABLE AND MUST BE USED ONLY FOR THE PURPOSE FOR WHICH THE DOCUMENT IS EXPRESSLY LOANED. THEY MUST NOT BE DISCLOSED, REPRODUCED, LOANED OR USED IN ANY OTHER MANNER WITHOUT THE EXPRESS WRITTEN CONSENT OF USF. IN NO EVENT SHALL THEY BE USED IN ANY MANNER DETRIMENTAL TO THE INTEREST OF USF. ALL PATENT RIGHTS ARE RESERVED. UPON THE DEMAND OF USF, THIS DOCUMENT, ALONG WITH ALL COPIES AND EXTRACTS, AND ALL RELATED NOTES AND ANALYSES, MUST BE RETURNED TO USF OR DESTROYED, AS INSTRUCTED BY USF. ACCEPTANCE OF THE DELIVERY OF THIS DOCUMENT CONSTITUTES AGREEMENT TO THESE TERMS AND CONDITIONS.

DESIGNER	DATE
LLR	4-8-01
CHECKER	DATE
ENGINEER	DATE
MANAGER	DATE
FILE:	
SCALE: NONE	

TITLE VSC200 GENERAL ASSEMBLY	
CLIENT TBD	
 USFILTER/WESTATES RED BLUFF, CA 1-800-795-2664	
PROJECT	DRAWING
VSC200GENASSY	VSC200GENASSY
SHEET OF	REV

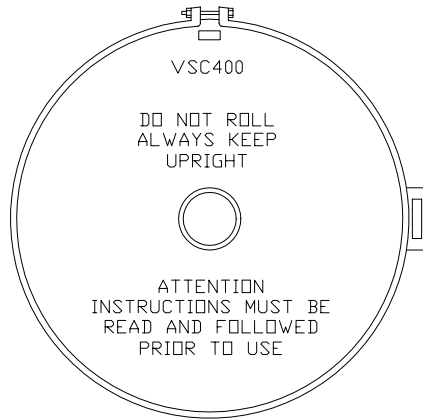

PLAN

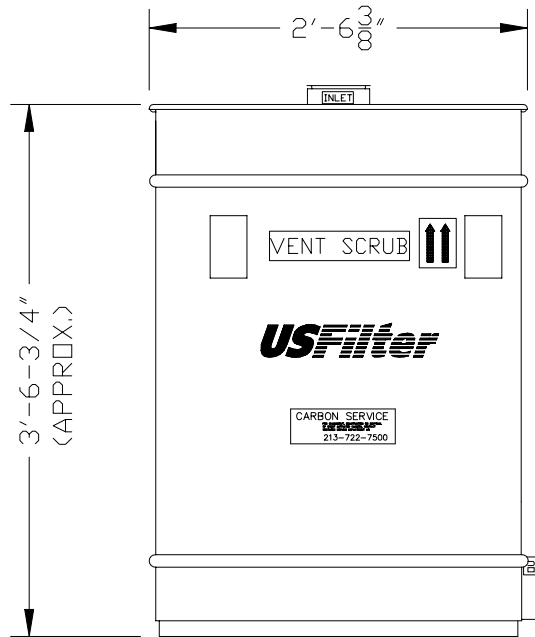

ELEVATION

**NOTES:**

1. CARBON:  
AS REQUIRED.
2. MATERIALS OF CONSTRUCTION:  
VESSEL: .....CARBON STEEL  
EXTERNAL COATING: .....HIGH GLOSS PAINT, WESTATES BLUE  
INTERNAL COATING: .....CURED EPOXY  
INTERNAL DISTRIBUTION: .....PVC
3. SPECIFICATIONS:  
FLOW \* - CFM (MAX): ..... 300  
PRESSURE - PSIG (MAX): ..... 6  
TEMPERATURE - DEG F (MAX): ..... 140  
CARBON FILL VOLUME - CU FT: ..... 14.0  
CROSS SECTION - SQ FT: ..... 4.9  
SHIPPING WEIGHT - LBS: (APPROX,) ..... 480  
OPERATING WEIGHT - LBS: (APPROX,) ..... 480

\* NOTE: ACTUAL DESIGN SHOULD BE BASED ON SUPERFICIAL BED VELOCITY (SBV) AS REQUIRED FOR SPECIFIC CONTAMINANTS.

COMPANY CONFIDENTIAL THIS DOCUMENT AND ALL INFORMATION CONTAINED HEREIN ARE THE PROPERTY OF THE USFILTER AND/OR ITS AFFILIATES ("USF"). THE DESIGN CONCEPTS AND INFORMATION CONTAINED HEREIN ARE PROPRIETARY TO USF AND ARE SUBMITTED IN CONFIDENCE. THEY ARE NOT TRANSFERABLE AND MUST BE USED ONLY FOR THE PURPOSE FOR WHICH THE DOCUMENT IS EXPRESSLY LOANED. THEY MUST NOT BE DISCLOSED, REPRODUCED, LOANED OR USED IN ANY OTHER MANNER WITHOUT THE EXPRESS WRITTEN CONSENT OF USF. IN NO EVENT SHALL THEY BE USED IN ANY MANNER DETRIMENTAL TO THE INTEREST OF USF. ALL PATENT RIGHTS ARE RESERVED. UPON THE DEMAND OF USF, THIS DOCUMENT, ALONG WITH ALL COPIES AND EXTRACTS, AND ALL RELATED NOTES AND ANALYSES, MUST BE RETURNED TO USF OR DESTROYED, AS INSTRUCTED BY USF. ACCEPTANCE OF THE DELIVERY OF THIS DOCUMENT CONSTITUTES AGREEMENT TO THESE TERMS AND CONDITIONS.	DESIGNER AJA	DATE 5-2-01	TITLE VSC400 GENERAL ASSEMBLY	
	CHECKER	DATE	CLIENT	
	ENGINEER	DATE	USFILTER/WESTATES RED BLUFF, CA 1-800-795-2664	
	MANAGER	DATE		
	FILE:	PROJECT		DRAWING VSC400.DWG
SCALE:				REV



LIST OF COMPONENTS

ITEM	QTY	DESCRIPTION
1	1	TANK ASSEMBLY
2	1	SKID ASSEMBLY
3	1	MANWAY ASSEMBLY, 18" DIA.
4	1	PLATE, I.D. & SERIAL NUMBER
5	1	BRONZE BALL VALVE, 3/4"
6	1	DECAL, "FOR VAPOR USE ONLY", 2 1/2" x 4 1/4"
7	2	DECAL, "VENT-SCRUB", WHITE MYLAR
8	2	DECAL, "15 PSIG MAX", WHITE MYLAR
9	2	DECAL, "USFILTER/WESTATES" WHITE MYLAR W/BUE LETTERS

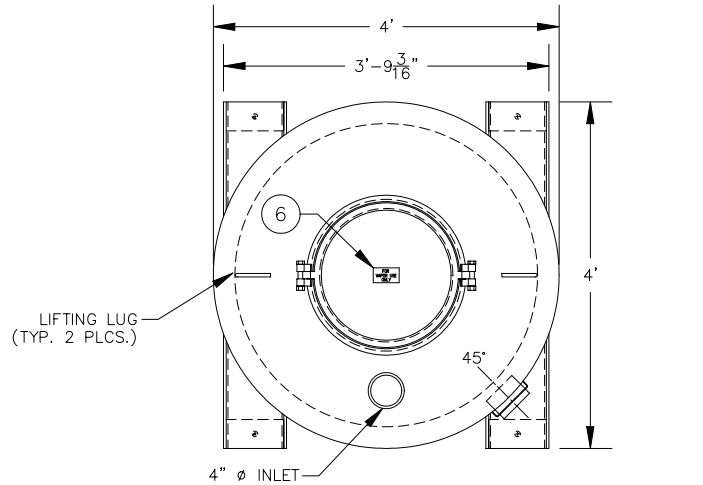

PLAN VIEW

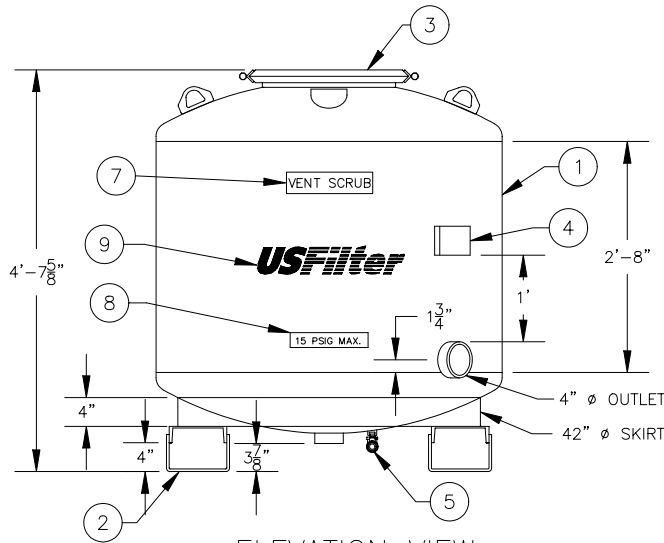

ELEVATION VIEW

NOTES:

- DESIGN DATA:**  
 48" DIAMETER PRESSURE VESSEL-15 PSIG(MAX)  
 VACUUM RATING - 15" HG  
 @ 120°F-NOT ASME CODE STAMPED FOR VAPOR USE ONLY  
 600 CFM  
 1000 LBS. ACTIVATED CARBON
- MATERIAL:**  
 HEADS - SA 36-HR  
 SHELL - SA 36-HR  
 SKID - SA 36-HR
- SURFACE PREPARATION:**  
**INTERIOR:**  
 SANDBLAST: SSPC-SP-5 WHITE METAL  
 ABRASIVE: GARNET OR GRIT - PROFILE: 1.5-2 MILS  
 COATING: 3M BRAND SCOTCHKOTE 134  
 THICKNESS: 10-15 DFMT - COLOR: GREEN  
**EXTERIOR:**  
 SANDBLAST: SSPC-SP-10 NEAR WHITE METAL  
 ABRASIVE: GARNET OR GRIT - PROFILE: 1.5-2 MILS  
 PRIMER COAT: RUST PREVENTATIVE EPOXY PRIMER (CARBOLINE 893)  
 THICKNESS: 4-6 DFMT - COLOR: RED  
 FINISH COAT: HIGH BUILD POLYURETHANE (CARBOLINE 134HG)  
 THICKNESS: 3-4 DFMT - COLOR: WHITE (FED. I.D.#17925)
- LIFTING REQUIREMENTS:**  
 5200 LBS. MINIMUM RATING.  
 EST. WEIGHTS:  
 890 LBS. - EMPTY VESSEL  
 1890 LBS. - WITH CARBON

COMPANY CONFIDENTIAL  
 THIS DOCUMENT AND ALL INFORMATION CONTAINED HEREIN ARE THE PROPERTY OF THE USFILTER AND/OR ITS AFFILIATES ("USF"). THE DESIGN CONCEPTS AND INFORMATION CONTAINED HEREIN ARE PROPRIETARY TO USF AND ARE SUBMITTED IN CONFIDENCE. THEY ARE NOT TRANSFERABLE AND MUST BE USED ONLY FOR THE PURPOSE FOR WHICH THE DOCUMENT IS EXPRESSLY LOANED. THEY MUST NOT BE DISCLOSED, REPRODUCED, LOANED OR USED IN ANY OTHER MANNER WITHOUT THE EXPRESS WRITTEN CONSENT OF USF. IN NO EVENT SHALL THEY BE USED IN ANY MANNER DETRIMENTAL TO THE INTEREST OF USF. ALL PATENT RIGHTS ARE RESERVED. UPON THE DEMAND OF USF, THIS DOCUMENT, ALONG WITH ALL COPIES AND EXTRACTS, AND ALL RELATED NOTES AND ANALYSES, MUST BE RETURNED TO USF OR DESTROYED, AS INSTRUCTED BY USF. ACCEPTANCE OF THE DELIVERY OF THIS DOCUMENT CONSTITUTES AGREEMENT TO THESE TERMS AND CONDITIONS.

DESIGNER	DATE
AJA	10-8-01
CHECKER	DATE
ENGINEER	DATE
MANAGER	DATE
FILE:	
SCALE: NONE	

TITLE		VSC1000 GENERAL ASSEMBLY	
CLIENT			
PROJECT		DRAWING	SHEET
		VSC1000SHEET1.DWG	1 OF 2
 USFILTER/WESTATES RED BLUFF, CA 1-800-795-2664		REV	

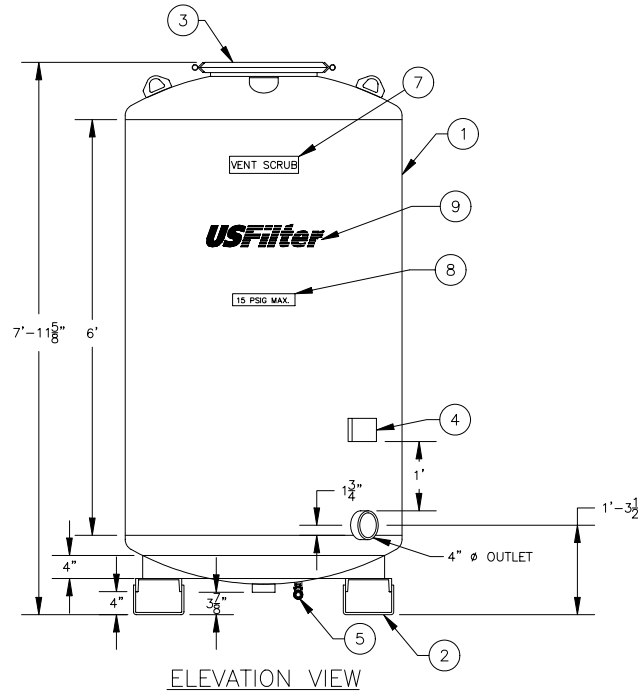
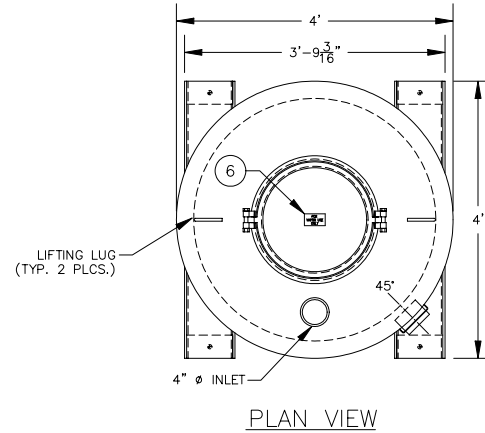

LIST OF COMPONENTS

ITEM	QTY	DESCRIPTION
1	1	TANK ASSEMBLY
2	1	SKID ASSEMBLY
3	1	MANWAY ASSEMBLY, 18" DIA.
4	1	PLATE, I.D. & SERIAL NUMBER
5	1	BRONZE BALL VALVE, 3/4"
6	1	DECAL, "FOR VAPOR USE ONLY", 2 1/2" x 4 1/4"
7	2	DECAL, "VENT -SCRUB", WHITE MYLAR
8	2	DECAL, "15 PSIG MAX", WHITE MYLAR
9	2	DECAL, "USFILTER/WESTATES" WHITE MYLAR W/BUE LETTERS

NOTES:

- DESIGN DATA:**  
 48" DIAMETER PRESSURE VESSEL-15 PSIG(MAX)  
 VACUUM RATING - 15" HG  
 @ 120°F-NOT ASME CODE STAMPED FOR VAPOR USE ONLY  
 600 CFM  
 2000 LBS. ACTIVATED CARBON
- MATERIAL:**  
 HEADS - SA 36-HR  
 SHELL - SA 36-HR  
 SKID - SA 36-HR
- SURFACE PREPARATION:**  
**INTERIOR:**  
 SANDBLAST: SSPC-SP-5 WHITE METAL  
 ABRASIVE: GARNET OR GRIT - PROFILE: 1.5-2 MILS  
 COATING: 3M BRAND SCOTCHKOTE 134  
 THICKNESS: 10-15 DFMT - COLOR: GREEN  
**EXTERIOR:**  
 SANDBLAST: SSPC-SP-10 NEAR WHITE METAL  
 ABRASIVE: GARNET OR GRIT - PROFILE: 1.5-2 MILS  
 PRIMER COAT: RUST PREVENTATIVE EPOXY PRIMER (CARBOLINE 893)  
 THICKNESS: 4-6 DFMT - COLOR: RED  
 FINISH COAT: HIGH BUILD POLYURETHANE (CARBOLINE 134HG)  
 THICKNESS: 3-4 DFMT - COLOR: WHITE (FED. I.D.#17925)
- LIFTING REQUIREMENTS:**  
 5200 LBS. MINIMUM RATING.  
 EST. WEIGHTS:  
 1190 LBS. - EMPTY VESSEL  
 3190 LBS. - WITH CARBON

COMPANY CONFIDENTIAL  
 THIS DOCUMENT AND ALL INFORMATION CONTAINED HEREIN ARE THE PROPERTY OF THE USFILTER AND/OR ITS AFFILIATES ("USF"). THE DESIGN CONCEPTS AND INFORMATION CONTAINED HEREIN ARE PROPRIETARY TO USF AND ARE SUBMITTED IN CONFIDENCE. THEY ARE NOT TRANSFERABLE AND MUST BE USED ONLY FOR THE PURPOSE FOR WHICH THE DOCUMENT IS EXPRESSLY LOANED. THEY MUST NOT BE DISCLOSED, REPRODUCED, LOANED OR USED IN ANY OTHER MANNER WITHOUT THE EXPRESS WRITTEN CONSENT OF USF. IN NO EVENT SHALL THEY BE USED IN ANY MANNER DETRIMENTAL TO THE INTEREST OF USF. ALL PATENT RIGHTS ARE RESERVED. UPON THE DEMAND OF USF, THIS DOCUMENT, ALONG WITH ALL COPIES AND EXTRACTS, AND ALL RELATED NOTES AND ANALYSES, MUST BE RETURNED TO USF OR DESTROYED, AS INSTRUCTED BY USF. ACCEPTANCE OF THE DELIVERY OF THIS DOCUMENT CONSTITUTES AGREEMENT TO THESE TERMS AND CONDITIONS.

DESIGNER	DATE
AJA	10-8-01
CHECKER	DATE
ENGINEER	DATE
MANAGER	DATE
FILE:	
SCALE: NONE	

TITLE	VSC2000 GENERAL ASSEMBLY		
CLIENT			
	 USFILTER/WESTATES RED BLUFF, CA 1-800-795-2664		
PROJECT	DRAWING	SHEET	REV
	VSC2000SHEET1.DWG	1 OF 5	

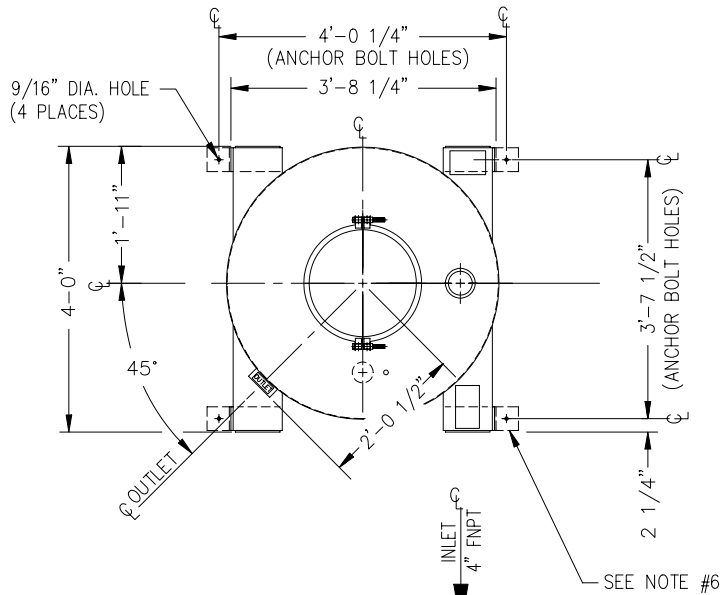

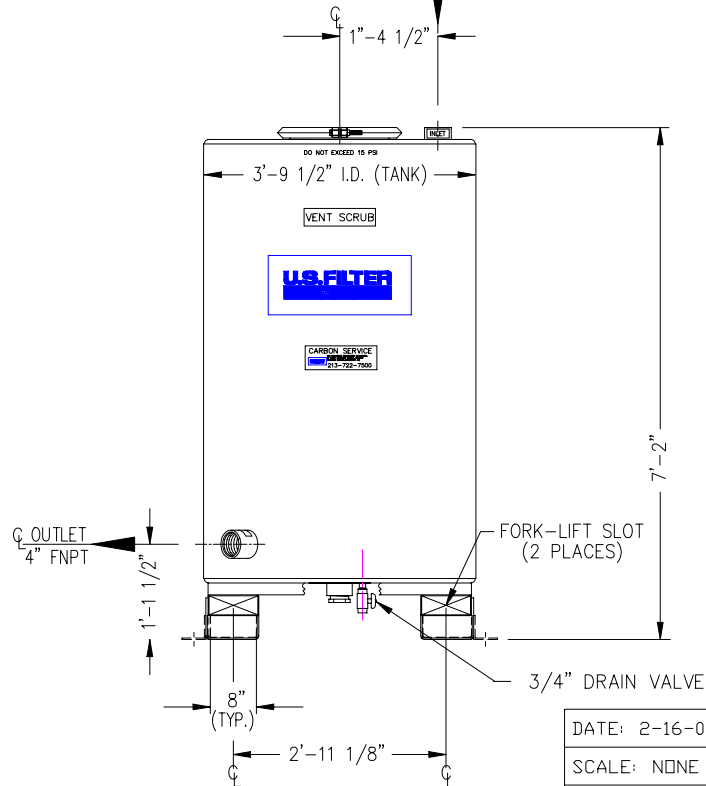

**NOTES:**

1. DESIGN DATA:  
 45 1/2" DIAMETER PRESSURE VESSEL – 15 PSIG (MAX)  
 @ 120°F – NOT ASME CODE STAMPED  
 FOR VAPOR USE ONLY, MAX. FLOW = 500 CFM  
 63 CU. FT. ACTIVATED CARBON  
 VACUUM = 6.0 INCH HG
2. MATERIAL:  
 HEADS – 7 GA. CARBON STEEL  
 SHELL – 10 GA. CARBON STEEL  
 SKID – CARBON STEEL
3. SURFACE PREPARATION:  
 INTERIOR COATING: FUSION BONDED EPOXY  
  
 EXTERIOR COATING: PRIMER: (2) PART EPOXY PRIMER  
 FINISH: ALIPHATIC POLYURETHANE FINISH, WHITE
4. APPROXIMATE WEIGHT:  
 EMPTY VESSEL: ..... 740 LBS
5. THIS VESSEL COMPLIES WITH UN 11A.
6. SHOWN WITH OPTIONAL SEIZMIC ZONE 4 HOLD-DOWN LUGS. (PART #A11098)



DATE: 2-16-01  
 SCALE: NONE  
 THIS DRAWING IS THE PROPERTY OF  
 USFILTER AND CANNOT BE RE-  
 PRODUCED OR DELIVERED TO OTHERS  
 WITHOUT THE EXPRESS WRITTEN  
 PERMISSION OF USFILTER CORP.

REV.	DATE	REVISION DESCRIPTION	DRAWN	CHK'D	ENG'R
CUSTOMER:		 	11711 Reading Road Red Bluff, CA 96080		
LOCATION:			TITLE: <b>VAPOR SCRUB ASSEMBLY VSC 2000</b>		
PROJECT No.		DWG No.		REV.	
DRAWN: AJA		VSC2000GENASSY.DWG			
CHK'D:					
ENG'R:					

NOTES:

1. DESIGN DATA:

60" DIAMETER PRESSURE VESSEL - 5 PSIG (MAX.)  
 @ 120°F - NOT ASME CODE STAMPED  
 FOR VAPOR USE ONLY, MAX. FLOW = 1,500 CFM  
 102 CU. FT. ACTIVATED CARBON

2. MATERIAL:

CARBON STEEL

3. SURFACE PREPARATION:

INTERIOR:

SANDBLAST: SSPC-5 WHITE METAL  
 ABRASIVE: STEEL GRIT - PROFILE 1.5-2.5 MILS

COATING: CARBOLINE 891  
 THICKNESS: 10-15 MILLS - COLOR: WHITE

EXTERIOR:

SANDBLAST: SSPC-10 NEAR WHITE METAL  
 ABRASIVE: STEEL GRIT - PROFILE 1.5-2.5 MILS

PRIMER COAT: CHEMICAL RESISTANCE CATALYZED EPOXY COATING  
 THICKNESS 3-5 MILS - COLOR: GREY

FINISH COAT: POLYURETHANE PROTECTIVE FINISH  
 THICKNESS 2-4 MILS - COLOR: WHITE  
 FEDERAL STANDARD COLOR 17925

4. APPROXIMATE WEIGHT:

EMPTY VESSEL: ..... 4,400 LBS  
 OPERATING ..... 7,400 LBS

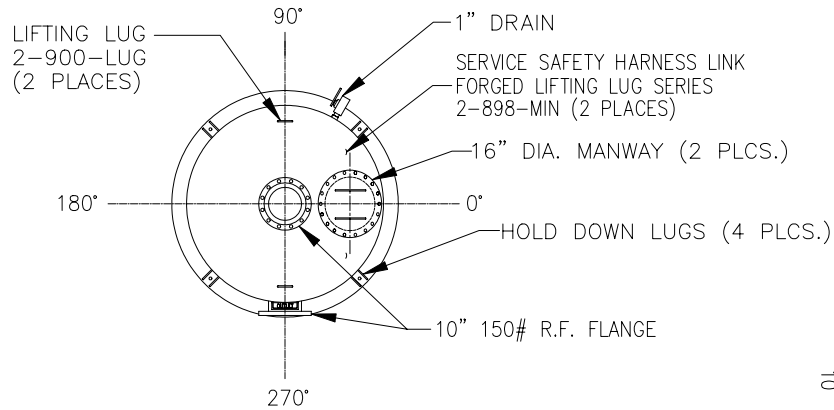

PLAN VIEW

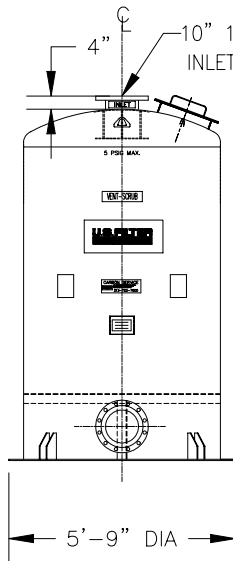

ELEVATION VIEW

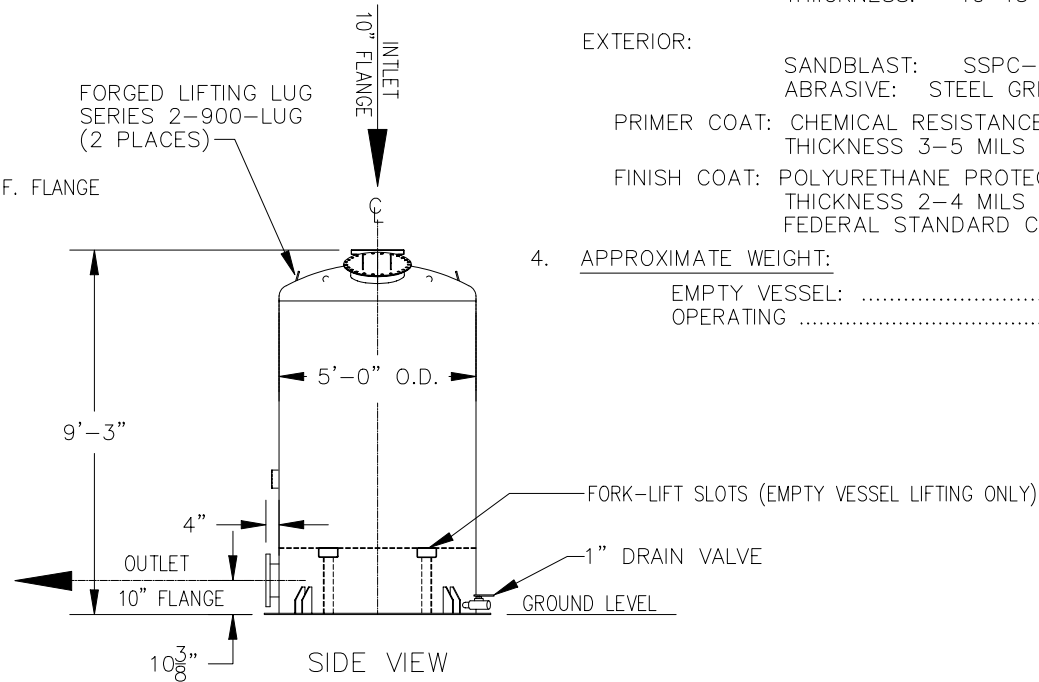

SIDE VIEW

COMPANY CONFIDENTIAL  
 THIS DOCUMENT AND ALL INFORMATION CONTAINED HEREIN ARE THE PROPERTY OF THE USFILTER AND/OR ITS AFFILIATES ("USF"). THE DESIGN CONCEPTS AND INFORMATION CONTAINED HEREIN ARE PROPRIETARY TO USF AND ARE SUBMITTED IN CONFIDENCE. THEY ARE NOT TRANSFERABLE AND MUST BE USED ONLY FOR THE PURPOSE FOR WHICH THE DOCUMENT IS EXPRESSLY LOANED. THEY MUST NOT BE DISCLOSED, REPRODUCED, LOANED OR USED IN ANY OTHER MANNER WITHOUT THE EXPRESS WRITTEN CONSENT OF USF. IN NO EVENT SHALL THEY BE USED IN ANY MANNER DETRIMENTAL TO THE INTEREST OF USF. ALL PATENT RIGHTS ARE RESERVED. UPON THE DEMAND OF USF, THIS DOCUMENT, ALONG WITH ALL COPIES AND EXTRACTS, AND ALL RELATED NOTES AND ANALYSES, MUST BE RETURNED TO USF OR DESTROYED, AS INSTRUCTED BY USF. ACCEPTANCE OF THE DELIVERY OF THIS DOCUMENT CONSTITUTES AGREEMENT TO THESE TERMS AND CONDITIONS.

DESIGNER LLR	DATE 7-6-01	TITLE VSC3000 GENERAL ASSEMBLY			
CHECKER	DATE	CLIENT			
ENGINEER	DATE	 USFILTER/WESTATES RED BLUFF, CA 1-800-795-2664			
MANAGER	DATE				
FILE:		PROJECT	DRAWING	SHEET	REV
SCALE: NONE		VSC3000GENASSY		OF	